



FW-120 and ILPanels

Technical/Product Information

IMPORTANT NOTICE

READ THIS MANUAL COMPLETELY PRIOR TO BEGINNING THE INSTALLATION OF THE FW-120 AND IL PANELS. THE MANUFACTURER DETAILS MUST BE FOLLOWED AS A MINIMUM TO INSURE APPROPRIATE WARRANTIES WILL BE ISSUED.

ALWAYS INSPECT EACH AND EVERY PANEL AND ALL ACCESSORIES BEFORE INSTALLATION. NEVER INSTALL ANY PRODUCT IF ITS QUALITY IS IN QUESTION. NOTIFY MBCI IMMEDIATELY IF ANY PRODUCT IS BELIEVED TO BE OUT OF TOLERANCE, SPECIFICATION OR HAS BEEN DAMAGED DURING SHIPMENT.

IF THERE IS A CONFLICT BETWEEN PROJECT INSTALLATION DRAWINGS PROVIDED OR APPROVED BY THE MANUFACTURER AND DETAILS IN THIS MANUAL, PROJECT INSTALLATION DRAWINGS WILL TAKE PRECEDENCE.

©Copyright NCI Group, Inc. All Rights Reserved. 06-2013

The engineering data contained herein is for the expressed use of customers and design professionals. Along with this data, it is recommended that the design professional have a copy of the most current version of the North American Specification for the Design of Cold-Formed Steel Structural Members published by the American Iron and Steel Institute to facilitate design. This Specification contains the design criteria for cold-formed steel components. Along with the Specification, the designer should reference the most current building code applicable to the project jobsite in order to determine environmental loads. If further information or guidance regarding cold-formed design practices is desired, please contact the manufacturer.

Descriptions and specifications contained herein were in effect at the time this publication was approved for printing. In a continuing effort to refine and improve products, MBCI reserves the right to discontinue products at any time or change specifications and/or designs without incurring obligations. **To insure you have the latest information available, please inquire or visit our Website at www.mbc.com.** Application details are for illustration purposes only and may not be appropriate for all environmental conditions, building designs, or panel profiles. Projects should be engineered to conform to applicable building codes, regulations, and accepted industry practices. Insulation is not shown in these details for clarity.

For complete performance specifications, product limitations, and disclaimers, please consult MBCI's Paint and Galvalume Plus® warranties. Upon receipt of payment in full, these warranties are available upon request for all painted or Galvalume Plus® prime products. Sample copies can be found at www.mbc.com or contact your local MBCI Sales Representative.

Houston, TX 877-713-6224
Adel, GA 888-446-6224
Atlanta, GA 877-512-6224
Atwater, CA 800-829-9324
Dallas, TX 800-653-6224

Indianapolis, IN 800-735-6224
Lubbock, TX 800-758-6224
Memphis, TN 800-206-6224
Oklahoma City, OK 800-597-6224
Omaha, NE 800-458-6224

Phoenix, AZ 888-533-6224
Richmond, VA 800-729-6224
Rome, NY 800-559-6224
Salt Lake City, UT 800-874-2404
San Antonio, TX 800-598-6224



TABLE OF CONTENTS

General Description.....	FW-4
Installation Guidelines	FW-5
Architect/Engineer Information	FW-6 - FW-8
Specifications	FW-9 - FW-11
Product Checklist	FW-12 - FW-15
Preparatory Requirements	FW-16
Unloading/Handling Information	FW-17 - FW-18
Architectural Details	
Panel Attachment.....	FW-19
Wall Splice	FW-20
Soffit Attachment.....	FW-21
Inside/Outside Corner	FW-22
Base Attachment.....	FW-23
Overhead Door Jamb/Header.....	FW-24
Walk Door Jamb/Header.....	FW-25
Window Sill/Header.....	FW-26
Window Jamb.....	FW-27
Jamb/Header Intersection	FW-28
Composite Wall System Details	
Panel Attachment.....	FW-29
Inside/Outside Corner	FW-30 - FW-31
Base Attachment.....	FW-32
Window/Door Jambs	FW-33
Window Head/Sill	FW-34
Jamb/Header Intersection	FW-35

General Information

FW-120 Panel

General Description

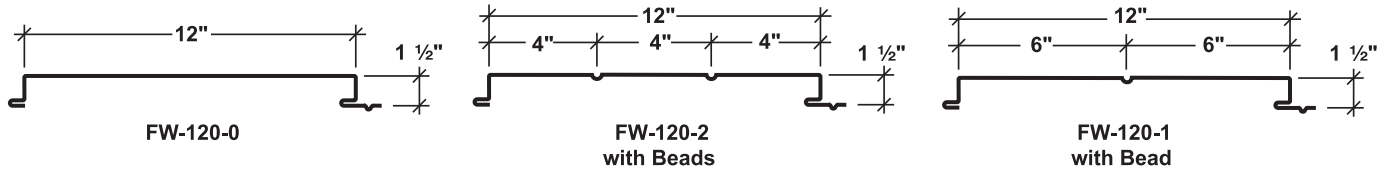

Coverage Width - 12"

Panel Attachment - See page FW-19

Panel Substrate - Galvalume® (standard)

Gauge - 24, 22, & 20

Finishes - Smooth or Embossed

Panel Female Leg - Factory sealant

PRODUCT SELECTION CHART

Panel Gauge	Signature® 300*	Signature® 300* Metallic	Signature® 200*	Galvalume Plus®
24	●	■	N/A	N/A
22	■	■	N/A	N/A
20	■	■	N/A	N/A

Signature is a registered trademark of NCI Group, Inc. Galvalume and Galvalume Plus are a registered trademark of BIEC International.

- - Available in any quantity.
- - Minimum quantity may be required.
- * - See architectural color chart for available colors.

FW-120 Panel

General Information

Installation Guidelines

- I. Pre-Order
 - A. **Prior to ordering panels, all dimensions should be confirmed by field measurement.**

- II. Jobsite Storage and Handling
 - A. Check the shipment against the shipping list.
 - B. Damaged material must be noted on Bill of Lading.
 - C. Panels should be handled carefully. A spreader bar of appropriate length is recommended for hoisting.
 - D. Check to see that moisture has not formed inside the bundles during shipment. If moisture is present, panels should be wiped dry, then restacked and loosely covered so that air can circulate between the panels.

- III. Application Checklist
 - A. Check substructure for proper alignment and uniformity to avoid panel distortion.
 - B. Periodic check of panel alignment is crucial to proper panel alignment.
 - C. Panels should be cut on the ground to minimize cut filings on roof. Keep panels clean during installation. Do not allow panels to come in contact with water runoff from lead, copper, or graphite.

Engineering

FW-120 Panel

Architect / Engineer Information

FW-120 Panel

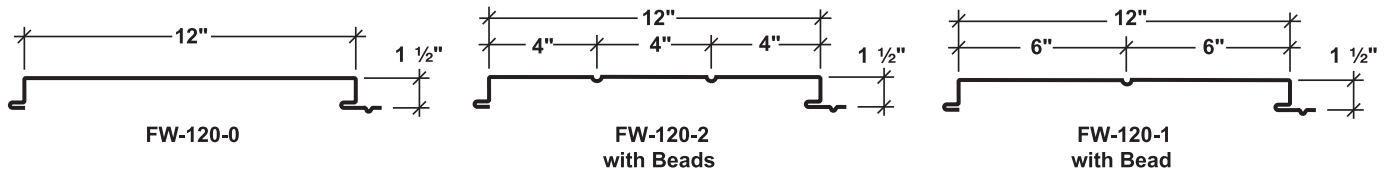

1. This concealed fastener profile offers an attractive, flat wall appearance for the architectural, commercial, and industrial market. The “FW” profile can be used both in a single skin application, as well as a composite wall system. The “FW” panel offers the option of “face beads”, and/or embossing.
2. “IL” Composite Wall System is pre-engineered to accommodate “FW” series panels as exterior skins with “IL” series interior liner.
3. All primary and secondary framing must be erected, plumbed, and squared with bolts tightened according to accepted building practices prior to beginning the installation of the FW-120 panel.
4. Wall girts, or structural to which the FW-120 panels are to be attached, must be properly aligned. Structural members that are not in alignment will induce stress into panels resulting in oil canning.
5. Heavier gauges and embossing minimizes oil canning. The industry standard for this product is 24 gauge material. **Oil Canning is not a cause for rejection.**
6. Panels may be spliced using MBCI’s splice trim. for continuous runs over 20'-0", please inquire.
7. All details and recommendations in this manual are for general guidelines only. Actual project conditions may require special treatment and/or changes in this information. Contact MBCI regarding deviations from the published standards. Suitability of use and manner of use of any product contained herein is the sole responsibility of the specifier.
8. Insulation is most effectively applied in the wall cavity behind the point of panel attachment. Semi-rigid or Rigid insulation can be inserted in the cavity of the panel between the vertical legs. Applying the panels over compressed blanket insulation can be difficult and may induce waviness or oil canning.

NOTES: A nominal 0.142 “U” value can be achieved when installed with 1 1/2" (1.50 PCF) fiberglass insulation. (Greater values can be achieved with thicker insulation.)

Insulated wall systems are field assembled. The “load tables” are designed for the exterior and interior panels in question. Other combinations of exterior panels, interior panels, and various insulation thicknesses are available upon request.

SECTION PROPERTIES								
PANEL GAUGE	F _y (KSI)	WEIGHT (PSF)	NEGATIVE BENDING			POSITIVE BENDING		
			I _{xe} (IN.4/FT.)	S _{xe} (IN.3/FT.)	Maxo (KIP-IN.)	I _{xe} (IN.4/FT.)	S _{xe} (IN.3/FT.)	Maxo (KIP-IN.)
24	50	1.54	0.0987	0.0824	2.4685	0.0441	0.0511	1.5275
22	50	1.85	0.1316	0.1106	3.3125	0.0617	0.0738	2.2110
20	50	2.16	0.1667	0.1401	4.1937	0.0824	0.1019	3.0496

NOTES:

1. Strength calculations based on the 2012 AISI Standard “North American Specification for the Design of Cold-Formed Steel Structural Members.”
2. I_{xe} is for deflection determination.
3. S_{xe} is for bending.
4. Maxo is allowable bending moment.
5. All values are for one foot of panel width.

FW-120 Panel Engineering

Architect / Engineer Information

FW-120 PANEL

ALLOWABLE UNIFORM LOADS IN POUNDS PER SQUARE FOOT

24 Gauge (Fy = 50 KSI)								
SPAN TYPE	LOAD TYPE	SPAN IN FEET						
		3.0	4.0	5.0	6.0	7.0	8.0	9.0
SINGLE	POSITIVE WIND LOAD	113.1	63.6	40.7	28.3	20.8	15.9	12.6
2-SPAN	POSITIVE WIND LOAD	104.8	61.5	39.9	27.9	20.6	15.8	12.5
3-SPAN	POSITIVE WIND LOAD	119.1	75.9	49.4	34.6	25.6	19.6	15.6
4-SPAN	POSITIVE WIND LOAD	114.6	71.2	46.2	32.4	23.9	18.4	14.5

22 Gauge (Fy = 50 KSI)								
SPAN TYPE	LOAD TYPE	SPAN IN FEET						
		3.0	4.0	5.0	6.0	7.0	8.0	9.0
SINGLE	POSITIVE WIND LOAD	163.8	92.1	59.0	40.9	30.1	23.0	18.2
2-SPAN	POSITIVE WIND LOAD	152.3	88.3	57.4	40.2	29.7	22.8	18.0
3-SPAN	POSITIVE WIND LOAD	184.9	108.5	70.9	49.8	36.8	28.3	22.5
4-SPAN	POSITIVE WIND LOAD	174.4	101.9	66.4	46.6	34.5	26.5	21.0

20 Gauge (Fy = 50 KSI)								
SPAN TYPE	LOAD TYPE	SPAN IN FEET						
		3.0	4.0	5.0	6.0	7.0	8.0	9.0
SINGLE	POSITIVE WIND LOAD	225.9	127.1	81.3	56.5	41.5	31.8	25.1
2-SPAN	POSITIVE WIND LOAD	206.4	120.5	78.6	55.1	40.8	31.3	24.8
3-SPAN	POSITIVE WIND LOAD	249.2	147.5	96.8	68.2	50.6	38.9	30.9
4-SPAN	POSITIVE WIND LOAD	235.5	138.7	90.9	63.9	47.3	36.4	28.9

NOTES:

- 1) Strength calculations based on the 2012 AISI Standard "North American Specification for the Design of Cold-Formed Steel Structural Members."
- 2) Allowable loads are applicable for uniform loading and spans without overhangs.
- 3) POSITIVE WIND LOAD capacities are for those loads that push the panel against its supports. The applicable limit states are flexure, shear, combined shear and flexure, web crippling at end and interior supports and a deflection limit of L/60.
- 4) The weight of the panel has not been deducted from the allowable loads.
- 5) THE ABOVE LOADS ARE NOT FOR USE WHEN DESIGNING PANELS TO RESIST WIND UPLIFT.
- 6) The use of any accessories other than those provided by the manufacturer may damage panels, void all warranties and will void engineering data.
- 7) This material is subject to change without notice. Please contact MBCI for the most current negative wind loads.

Engineering

IL Panel

Architect / Engineer Information IL Panel

1. "IL" Liner Installation: Attach fasteners at base girt or base angle and at all wall girts as shown in this manual.
2. Fastener selection is dictated by building codes, type of material used, and building requirements. Consult a structural engineer for proper fastener selection.

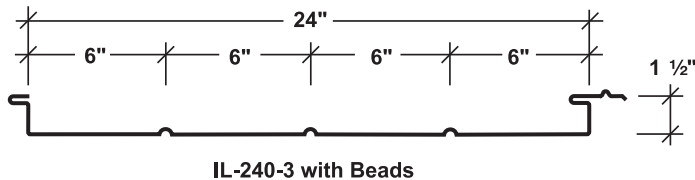
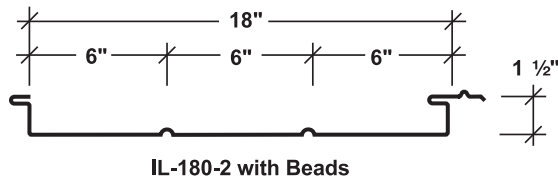
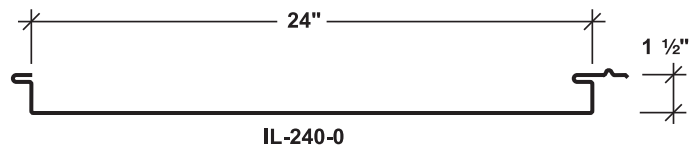
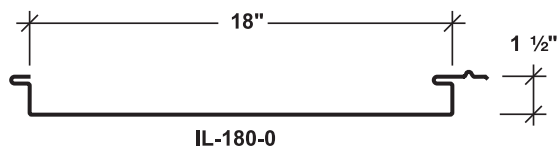

FW-120 Panel Specifications

MBCI FW-120 Formed Metal Wall Panels

The FW-120 panel is a concealed fastener wall and liner panel that provides a flat appearance. FW-120 is commonly used for architectural, commercial and industrial markets. The heavy gauge offering provides for large spanning capabilities, particularly in composite wall applications. FW-120 is available in a flat profile, with one stiffening bead, or with two stiffening beads, in smooth and embossed metal surfaces.

The FW-120 Panel has been tested by a certified independent laboratory in accordance with ASTM test procedures for Air Infiltration and Water Penetration at the side lap. Test results show no air leakage at 1.57PSF and no water penetration at 6.24PSF differential pressure.

This guide specification section includes optional MBCI IL interior liner panels for use in a complete MBCI Composite Wall System. The Composite Wall System is designed to accommodate FW or 7.2 panels as exterior skins with IL Panel interiors. The IL Panel is ideal for an interior liner creating a rugged and attractive finished wall appearance. This panel features a concealed fastened system. The IL Panel profile allows for installation as the liner of a composite wall system or installed to the inside girts of a building. The IL Panel is not recommended for exterior applications.

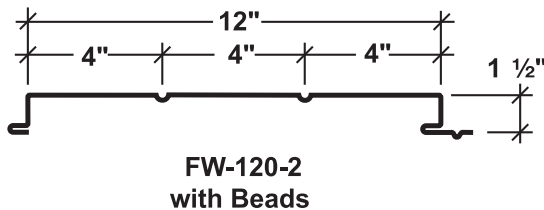
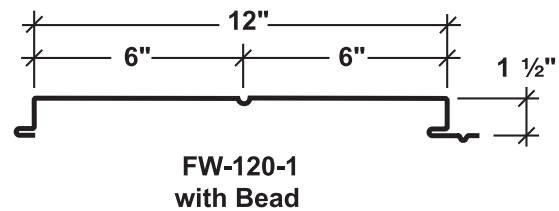
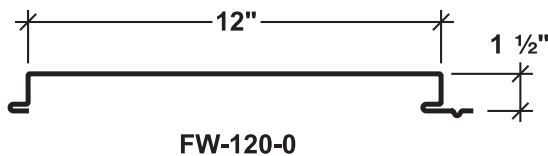

MBCI offers four separate concealed fastener wall panels, the Designer Series, ShadowRib™, NuWall® and the FW Panel. The Designer Series panels are concealed fastener wall panels available in two distinct profiles, flat and fluted. The ShadowRib panel combines aesthetics, economy and function to bring definition to metal structures. NuWall, a tertiary concealed fastener wall panel from MBCI, combines the ease of installation in both new and retrofit applications with a pleasing aesthetic appeal. NuWall is ideal for both new and retrofit construction. Finally, the FW Panel can be used in single skin applications or as a component of composite wall systems.

MBCI manufactures metal panels with the most technologically advanced manufacturing line in the United States. Our metal panel finish offerings allow for a multitude of design opportunities. Whether you're an architect looking for the best design solution, a contractor in need of efficient materials that are easy to install or a building owner looking to save money on maintenance costs, our panels make the difference.

Consult your local MBCI sales representative for design assistance. Visit www.mbc.com for a list of MBCI office locations and contacts. ShadowRib™ is a trademark of Metal Building Components, Inc. (MBCI). NuWall® is a registered trademark of Metal Building Components, Inc. (MBCI); This document is Copyright© 2012 MBCI.

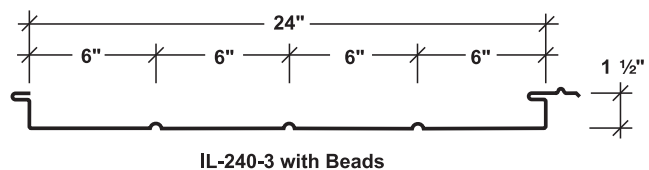
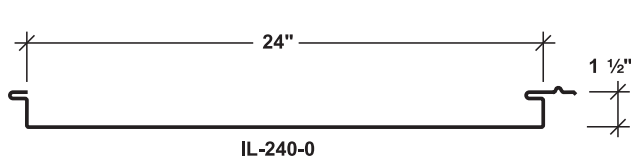
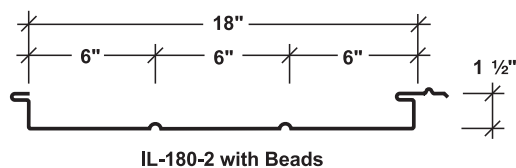
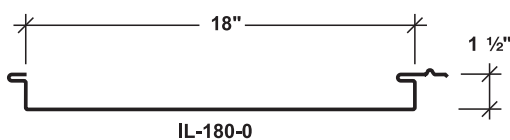

Specifications

FW-120 Panel

PART 1 - GENERAL

1.1 SECTION INCLUDES

- A. Flush-profile, concealed fastener metal wall panels, with related [liner panels,] metal trim, and accessories.

1.2 RELATED REQUIREMENTS

Specifier: If retaining this optional article, edit list below to correspond to Project.

- A. Division 01 Section "Sustainable Design Requirements" for related LEED general requirements.
B. Division 05 Section "Structural Steel Framing" for steel framing supporting metal panels.
C. Division 05 Section "Cold-Formed Metal Framing" for cold-formed metal framing supporting metal panels.
D. Division 07 Section "Thermal Insulation" for thermal insulation installed behind metal panels.
E. Division 07 Section "Air Barriers" for air barriers within wall assembly and adjacent to wall assembly.
F. Division 07 Section "Metal Soffit Panels" for soffit panels installed with metal wall panels.
G. Division 07 Section "Sheet Metal Flashing and Trim" for sheet metal flashing items in addition to items specified in this Section.
H. Division 13 Section "Metal Building Systems" for steel framing supporting metal panels.

1.3 REFERENCES

Specifier: If retaining this optional article, edit list below to correspond to Project.

- A. American Architectural Manufacturer's Association (AAMA): www.aamanet.org;
1. AAMA 621 - Voluntary Specifications for High Performance Organic Coatings on Coil Coated Architectural Hot Dipped Galvanized (HDG) & Zinc-Aluminum Coated Steel Substrates.
2. AAMA 809.2 Voluntary Specification Non-Drying Sealants.
B. American Society of Civil Engineers (ASCE): www.asce.org/codes-standards;
1. ASCE 7 - Minimum Design Loads for Buildings and Other Structures.
C. ASTM International (ASTM): www.astm.org;
1. ASTM A755 - Specification for Steel Sheet, Metallic Coated by the Hot-Dip Process and Prepainted by the Coil-Coating process for Exterior Exposed Building Products.
2. ASTM A792/A792M - Standard Specification for Steel Sheet, 55% Aluminum-Zinc Alloy-Coated by the Hot-Dip Process.
3. ASTM C920 - Specification for Elastomeric Joint Sealants.
4. ASTM D2244 - Test Method for Calculation of Color Differences from Instrumentally Measured Color Coordinates.
5. ASTM D4214 - Test Methods for Evaluating Degree of Chalking of Exterior Paint Films.
6. ASTM E283 - Standard Test Method for Determining Rate of Air Leakage Through Exterior Windows, Curtain Walls, and Doors Under Specified Pressure Differences Across the Specimen.
7. ASTM E331 - Standard Test Method for Water Penetration of Exterior Windows, Skylights, Doors, and Curtain Walls by Uniform Static Air Pressure Difference.
8. ASTM E1592 - Standard Test Method for Structural Performance of Sheet Metal Roof and Siding Systems by Uniform Static Air Pressure Difference.
D. International Accreditation Service (IAS):
1. IAS AC472 Accreditation Criteria for Inspection Programs for Manufacturers of Metal Building Systems, Part B.
E. US Green Building Council (USGBC): www.usgbc.org;
1. Leadership in Energy and Environmental Design (LEED) Green Building Rating System.

1.4 QUALITY ASSURANCE

- A. Manufacturer/Source: Provide metal panel assemblies and accessories from a single manufacturer accredited under IAS AC472, Part B.
B. Manufacturer Qualifications: Approved manufacturer listed in this

Section with minimum five years experience in manufacture of similar products in successful use in similar applications.

Specifier: Retain paragraph below if Owner allows substitutions but requires control over qualifying of substituted manufacturers.

1. Approval of Comparable Products: Submit the following in accordance with project substitution requirements, within time allowed for substitution review:
 - a. Product data, including certified independent test data indicating compliance with requirements.
 - b. Samples of each component.
 - c. Sample shop drawings from similar project.
 - d. Project References: Minimum of five installations not less than three years old, with Owner and Architect contact information.
 - e. Sample warranty.
 - f. Certificate of accreditation under IAS AC472 Part B.
2. Substitutions following award of contract are not allowed except as stipulated in Division 01 General Requirements.
3. Approved manufacturers must meet separate requirements of Submittals Article.

Specifier: Review of manufacturers' qualifying of installers is recommended. MBCI requires Installer and supervisor certification when project requirements include extended warranty.

- C. Installer Qualifications: Experienced Installer [certified by metal panel manufacturer] with minimum of five years experience with successfully completed projects of a similar nature and scope.
1. Installer's Field Supervisor: Experienced mechanic [certified by metal panel manufacturer] supervising work on site whenever work is underway.

Specifier: Retain paragraph below and edit as appropriate for Federal projects and for public works projects utilizing Federal funds; consult with project Contracting Officer. Coordinate with Submittals Article.

- D. Buy American Compliance: Materials provided under work of this Section shall comply with the following requirements:
1. Buy American Act of 1933 BAA-41 U.S.C §§ 10a – 10d.
2. Buy American provisions of Section 1605 of the American Recovery and Reinvestment Act of 2009 (ARRA).
E. Steel Construction Publications: Comply with published recommendations in the following, unless more stringent requirements are indicated.
1. American Institute of Steel Construction (AISC): "Steel Construction Manual."
2. American Iron and Steel Institute (AISI): "Cold Formed Steel Design Manual."

1.5 ADMINISTRATIVE REQUIREMENTS

- A. Preinstallation Meeting: Prior to erection of framing, conduct preinstallation meeting at site attended by Owner, Architect, metal panel installer, metal panel manufacturer's technical representative, inspection agency and related trade contractors.
1. Coordinate building framing in relation to metal panel system.
2. Coordinate openings and penetrations of metal panel system.
3. Coordinate work of Division 07 Sections "Roof Specialties" and "Roof Accessories" and openings and penetrations and manufacturer's accessories with installation of metal panels.

1.6 ACTION SUBMITTALS

- A. Product Data: Manufacturer's data sheets for specified products. Include data indicating compliance with performance requirements.

Specifier: Retain and edit below to comply with Project requirements for LEED or other sustainable design requirements.

B. LEED Submittals:

1. Credit MR 4 Recycled Content: Product data indicating the following:
 - a. Material costs for each product having recycled content.
 - b. Percentages by weight of post-consumer and pre-consumer

FW-120 Panel

recycled content for each item.

- c. Total weight of products provided.
 2. Credit IEQ 4.1 Low-Emitting Materials - Adhesives and Sealants: Product data for sealants and sealant primers used inside the weatherproofing system, indicating VOC content.
 - C. Shop Drawings: Show layouts of metal panels. Include details of each condition of installation, panel profiles, and attachment to building. Provide details at a minimum scale 1-1/2-inch per foot of edge conditions, joints, fastener and sealant placement, flashings, openings, penetrations, and special details. Make distinctions between factory and field assembled work.
 1. Indicate points of supporting structure that must coordinate with metal panel system installation.
 2. Include structural data indicating compliance with performance requirements and requirements of local authorities having jurisdiction.
 - D. Samples for Initial Selection: For each exposed product specified including sealants. Provide representative color charts of manufacturer's full range of colors.
 - E. Samples for Verification: Provide 12-inch- (305 mm-) long section of each metal panel profile. Provide color chip verifying color selection.
- 1.7 INFORMATIONAL SUBMITTALS
- A. Product Test Reports: Indicating compliance of products with requirements.
 - B. Qualification Information: For Installer firm and Installer's field supervisor.
 - C. IAS Accreditation Certificate: Indicating that manufacturer is accredited under provisions of IAS AC472 Part B.
 - D. Buy American Certification: Manufacturers' letters of compliance acceptable to authorities having jurisdiction, indicating that products comply with requirements.
 - E. Florida State Building Code Certificate: Indicating that products comply with requirements of Florida State Building Code. www.floridabuilding.org/pr/pr_app_srch.aspx
 - F. Manufacturer's warranty: Unexecuted sample copy of manufacturer's warranty.
- 1.8 CLOSEOUT SUBMITTALS
- A. Maintenance data.
 - B. Manufacturer's Warranty: Executed copy of manufacturer's warranty.
- 1.9 DELIVERY, STORAGE, AND HANDLING
- A. Protect products of metal panel system during shipping, handling, and storage to prevent staining, denting, deterioration of components or other damage. Protect panels and trim bundles during shipping.
 1. Deliver, unload, store, and erect metal panels and accessory items without misshaping panels or exposing panels to surface damage from weather or construction operations.
 2. Store in accordance with Manufacturer's written instruction. Provide wood collars for stacking and handling in the field.
 3. Shield foam insulated metal panels from direct sunlight until installation.
- 1.10 WARRANTY
- Specifier: Warranty terms below are available from MBCI. Verify that other allowable manufacturers furnish warranty meeting requirements.
- A. Special Manufacturer's Warranty: On manufacturer's standard form, in which manufacturer agrees to repair or replace metal panel assemblies that fail in materials and workmanship within [one] year from date of Substantial Completion.
 - B. Special Panel Finish Warranty: On Manufacturer's standard form, in which Manufacturer agrees to repair or replace metal panels that evidence deterioration of factory-applied finish within the warranty period, as follows:

Specifier: Retain finish warranty paragraph that corresponds to selected metal panel finish system. Several exotic and metallic colors are available from MBCI with limited warranty periods; verify warranty period for selected colors with manufacturer.

1. Fluoropolymer Two-Coat System:
 - a. Basis of Design System: MBCI, Signature 300.
 - b. Color fading in excess of 5 Hunter units per ASTM D2244.
 - c. Chalking in excess of No. 8 rating per ASTM D4214.
 - d. Failure of adhesion, peeling, checking, or cracking.
 - e. Warranty Period: [40] years from date of Substantial Completion.
2. Modified Silicone-Polyester Two-Coat System:
 - a. Basis of Design System: MBCI, Signature 200.
 - b. Color fading in excess of 7 Hunter units per ASTM D2244.
 - c. Chalking in excess of No. 6 rating per ASTM D4214.
 - d. Failure of adhesion, peeling, checking, or cracking.
 - e. Warranty Period: [30] years from date of Substantial Completion.

PART 2 - PRODUCTS

2.1 MANUFACTURER

Specifier: Retain basis of design manufacturer and products listed in this Article where allowed. If inserting comparable manufacturers, carefully review products and engineering capabilities in relation to requirements of this Section, to ensure that other approved manufacturers offer products meeting MBCI's standards.

- A. Basis of Design Manufacturer: MBCI Metal Roof and Wall Systems, Division of NCI Group, Inc.; Houston TX. Tel: (877)713-6224; Email: info@mbcicom.com; Web: www.mbcicom.com.
 1. Provide basis of design product[, or comparable product approved by Architect prior to bid].

2.2 PERFORMANCE REQUIREMENTS

- A. General: Provide metal panel system meeting performance requirements as determined by application of specified tests by a qualified testing facility on manufacturer's standard assemblies.

Specifier: "Recycled Content" Paragraph below describes calculation utilized for LEED-NC Credit MR 4. Modify as required to meet project recycled content requirements, or delete if recycled content requirements are stipulated solely in Division 01 Section "Sustainable Design Requirements."

- B. Recycled Content: For Steel Products: Postconsumer recycled content plus one-half of preconsumer recycled content not less than [25] percent.
- C. Structural Performance: Provide metal panel assemblies capable of withstanding the effects of indicated loads and stresses within limits and under conditions indicated, as determined by ASTM E1592:

Specifier: Consult structural engineer and edit below as required by local codes. Insert structural data below if not indicated on drawings. Select applicable deflection limit.

1. Wind Loads: Determine loads based on uniform pressure, importance factor, exposure category, and basic wind speed indicated on drawings.
 - a. Wind Negative Pressure: Certify capacity of metal panels by actual testing of proposed assembly.
2. Deflection Limits: Withstand inward and outward wind-load design pressures in accordance with applicable building code with maximum deflection of 1/120 of the span with no evidence of failure.
3. Seismic Performance: Comply with ASCE 7 Sections 9, "Earthquake Loads."
- D. Florida State Building Code Compliance: Provide metal roof and wall panels complying with requirements for installation under Florida State Building Code outside of high velocity wind zone.
- E. Wall Panel Air Infiltration, ASTM E283:
 1. No air infiltration at static-air-pressure difference of 1.57 lbf/sq. ft. (75 Pa).
- F. Wall Panel Water Penetration Static Pressure, ASTM E331: No uncontrolled water penetration at a static pressure of 6.24 lbf/sq. ft. (300 Pa).

Product Information

FW-120 Panel

G. Thermal Movements: Allow for thermal movements from variations in both ambient and internal temperatures. Accommodate movement of support structure caused by thermal expansion and contraction. Allow for deflection and design for thermal stresses caused by temperature differences from one side of the panel to the other.

2.3 FORMED METAL WALL PANELS

- A. Flush-Profile, Concealed Fastener Metal Wall Panels: Structural metal panels consisting of formed metal sheet with vertical panel edges and [flat pan] [one intermediate stiffening bead, symmetrically placed] [two intermediate stiffening beads, symmetrically placed], with flush joints between panels, field assembled with nested lapped edges, and attached to supports using concealed fasteners.
1. Basis of Design: MBCI, FW-120 Panel.

Specifier: Material description below corresponds to BIEC International, Inc. <http://galvalume.com/> Galvalume substrate, available Prepainted from MBCI. Second paragraph below describes Galvalume Plus with clear acrylic coating for use as exposed metallic finish.

2. Aluminum-Zinc Alloy-Coated Steel Sheet: ASTM A792/A792M, structural quality, Grade 50, Coating Class AZ50 (Grade 340, Coating Class AZM150), prepainted by the coil-coating process per ASTM A755/A755M. Specifier: Prior to selecting metal thickness and panel thickness below, consult manufacturer's span tables and review selection against panel thickness requirements and span condition. Select appropriate panel configuration to meet requirements of design wind pressure. Important: Consult this document when specifying gauge with the intent that it meet a prescriptive decimal thickness requirement in addition to strength performance requirements. (Click Here to View)

- a. Nominal Thickness: [24 gage] [22 gage] [20 gage] coated thickness, with [smooth] [stucco embossed] surface.
 - 1) Exterior Finish: [Modified silicone-polyester two-coat system] [Fluoropolymer two-coat system] [Fluoropolymer two-coat metallic color system] [Exposed Galvalume Plus coating].
 - 2) Color: [As indicated] [As selected by Architect from manufacturer's standard colors] [Match Architect's custom color].
 - 3) Panel Width: 12 inches (305 mm).
 - 4) Panel Thickness: 1-1/2 inch (38 mm).

2.4 METAL WALL LINER PANELS

Specifier: MBCI IL concealed fastener interior wall and liner panels offer an attractive, flat appearance for architectural, commercial and industrial markets. The heavy gauge offering of each interior wall and liner panel, available in 24, 22 and 20 gauge, provides for large spanning capabilities, particularly in composite wall applications.

- A. Flush-Profile, Concealed Fastener Metal Liner Panels: Structural metal panels consisting of formed metal sheet with vertical panel edges and [flat pan] [two intermediate stiffening beads, symmetrically placed] [three intermediate stiffening beads, symmetrically placed], with flush joints between panels, field assembled with [interlocking] lapped edges, and attached to supports using concealed fasteners.
1. Basis of Design: MBCI, IL Panel.
 2. Aluminum-Zinc Alloy-Coated Steel Sheet: ASTM A792/A792M, structural quality, Grade 50, Coating Class AZ50 (Grade 340, Coating Class AZM150), prepainted by the coil-coating process per ASTM A755/A755M.

Specifier: Prior to selecting metal thickness and panel thickness below, consult manufacturer's span tables and review selection against panel thickness requirements and span condition. Select appropriate panel configuration to meet in-service requirements. Formed metal wall

panels do not provide diaphragm strength for building stability. Important: Consult this document when specifying gauge with the intent that it meet a prescriptive decimal thickness requirement in addition to strength performance requirements. (Click Here to View)

- a. Nominal Thickness: [24 gauge] [22 gauge] coated thickness, with [smooth] [stucco embossed] surface.
 - 1) Finish: Modified silicone-polyester two-coat system.
 - 2) Color: [As indicated] [As selected by Architect from manufacturer's standard colors] [Match Architect's custom color].
 - 3) Panel Width: [18 inches (457 mm)] [24 inches (610 mm)].
 - 4) Panel Thickness: 1-1/2 inch (38 mm).

2.5 MISCELLANEOUS MATERIALS

- A. General: Provide complete metal panel assemblies incorporating trim, copings, fasciae, gutters and downspouts, and miscellaneous flashings. Provide required fasteners, closure strips, and sealants

as

indicated in manufacturer's written instructions.

- B. Flashing and Trim: Match material, thickness, and finish of metal panels.
- C. Panel Fasteners: Self-tapping screws and other acceptable fasteners recommended by metal panel manufacturer. Where exposed fasteners cannot be avoided, supply corrosion-resistant fasteners with heads matching color of metal panels by means of factory-applied coating, with weathertight resilient washers.
- D. Panel Sealants:
 1. VOC Content of Interior Sealants: Sealants used inside the weatherproofing system shall comply with the following limits for VOC content when calculated according to 40 CFR 59, Subpart D (EPA Method 24):
 - a. Architectural Sealants: 250 g/L.
 2. Factory-Applied Seam Sealant: Manufacturer's standard hot-melt type.
 3. Concealed Joint Sealant: Non-curing butyl, AAMA 809.2.
 4. Elastomeric Joint Sealant: Urethane sealant, single-component, ASTM C920 Type S, Grade NS, Class 25, Use NT, A, M, G, O.
 5. Foam Tape: Manufacturer's standard self-adhering type.

2.6 FABRICATION

- A. General: Provide factory fabricated and finished metal panels, trim, and accessories meeting performance requirements, indicated profiles, and structural requirements.
- B. Sheet Metal Flashing and Trim: Fabricate flashing and trim to comply with manufacturer's written instructions, approved shop drawings, and project drawings.

2.7 FINISHES

- A. Finishes, General: Prepare, pretreat, and apply coating to exposed metal surfaces to comply with coating and resin manufacturers' written instructions.
- B. Modified Silicone-Polyester Two-Coat System: 0.20 – 0.25 mil primer with 0.7 – 0.8 mil color coat[, meeting solar reflectance index requirements].
 1. Basis of Design: MBCI, Signature 200.

Specifier: MBCI's fluoropolymer coatings are based on Arkema, Inc. Kynar 500 and Solvay Solexis Hylar 500 PVF2 resins.

- C. Fluoropolymer Two-Coat System: 0.2 – 0.3 mil primer with 0.7 - 0.8 mil 70 percent PVDF fluoropolymer color coat, AAMA 621[, meeting solar reflectance index requirements].
 1. Basis of Design: MBCI, Signature 300.

PART 3 - EXECUTION

3.1 EXAMINATION

- A. Examine metal panel system substrate with Installer present. Inspect for erection tolerances and other conditions that would adversely affect installation of metal panels.
1. Inspect framing that will support insulated metal panels to determine if support components are installed as indicated

FW-120 Panel

Product Information

on approved shop drawings and are within tolerances acceptable to metal panel manufacturer and installer. Confirm presence of acceptable framing members at recommended spacing to match installation requirements of metal panels.

- B. Correct out-of-tolerance work and other deficient conditions prior to proceeding with insulated metal panel installation.

3.2 METAL PANEL INSTALLATION

- A. Concealed-Fastener Formed Metal Panels: Install metal panel system in accordance with manufacturer's written instructions, approved shop drawings, project drawings, and referenced publications. Install metal panels in orientation, sizes, and locations indicated. Anchor panels and other components securely in place. Provide for thermal and structural movement.
- B. Fasten metal panels to supports with fasteners at each location indicated on approved shop drawings, at spacing and with fasteners recommended by manufacturer. Fasten panel to support structure through leading flange. Snap-fit back flange of subsequent panel into secured flange of previous panel. Where indicated, fasten panels together through flush-fitted panel sides.
1. Cut panels in field where required using manufacturer's recommended methods.
 2. Dissimilar Materials: Where elements of metal panel system will come into contact with dissimilar materials, treat faces and edges in contact with dissimilar materials as recommended by metal panel manufacturer.
- C. Attach panel flashing trim pieces to supports using recommended fasteners and joint sealers.
- D. Joint Sealers: Install liquid sealants where indicated and where required for weatherproof performance of metal panel assemblies.
1. Seal panel base assembly, openings, panel head joints, and perimeter joints using joint sealers indicated in manufacturer's instructions.
 2. Seal perimeter joints between window and door openings and adjacent panels using elastomeric joint sealer.
 3. Prepare joints and apply sealants per requirements of Division 07 Section "Joint Sealants."

3.3 ACCESSORY INSTALLATION

- A. General: Install metal panel accessories with positive anchorage to building and weather tight mounting; provide for thermal expansion. Coordinate installation with flashings and other components.
1. Install components required for a complete metal panel assembly, including trim, copings, flashings, sealants, closure strips, and similar items.
 2. Comply with details of assemblies utilized to establish compliance with performance requirements and manufacturer's written installation instructions.
 3. Set units true to line and level as indicated. Install work with laps, joints, and seams that will be permanently weather resistant.

3.4 CLEANING AND PROTECTION

- A. Clean finished surfaces as recommended by metal panel manufacturer.
- B. Replace damaged panels and accessories that cannot be repaired to the satisfaction of the Architect.

END OF SECTION

General Information

FW-120/IL Panel

Product Checklist

FW Panel

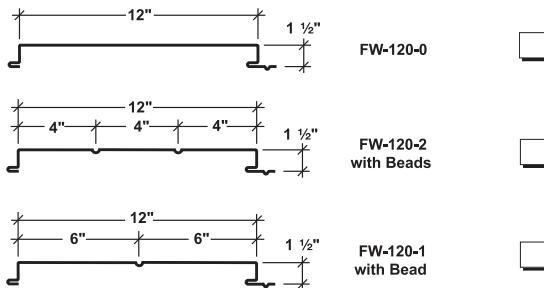

IL Panel

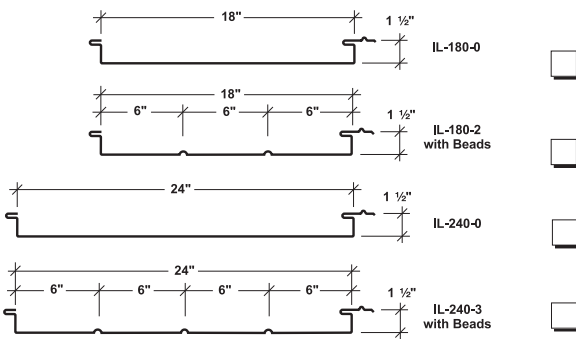

Tube Sealant

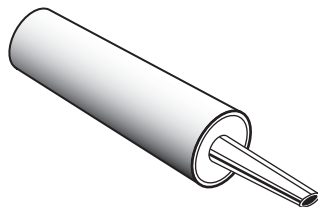

- HW-540 Urethane White
- HW-544 Urethane Almond
- HW-542 Urethane Bronze

1/2" x 3/32" Tape sealer

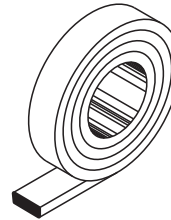

HW-507

Fastener #1



1/4"-14 x 1" Self Driller
5/16" Hex Washer Head, with 5/8" O.D. washer

Fastener #1A



12-14 x 1" Self Driller
5/16" Hex Washer Head, with no washer

Fastener #4

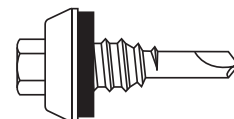

1/4"-14 x 7/8" Long Life Lap Tek Self Driller
5/16" Hex Washer Head, with sealing washer

FW-120/IL Panel General Information

Product Checklist

Fastener #4A

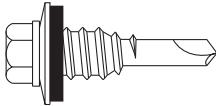

1/4"-14 x 7/8" Lap Tek Self Driller
 5/16" Hex Washer Head, with 5/8" O.D. washer

Fastener #14

- Trim to trim connections
- Stainless steel



Pop Rivet 1/8" diameter x 3/16" grip range

Fastener #11

- Special application fastener
- For use on masonry

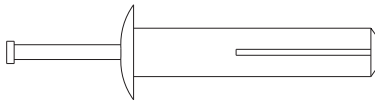

1/4"-1 1/4" Nail Drive
 Masonry Anchor

Fastener #14A



Pop Rivet 1/2" diameter x 3/8" grip range

Fastener #12A

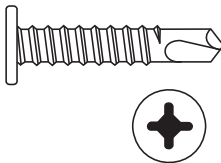

12 x 1" #2 Phillips/Square Drive
 Pancake Head Self Driller

Eave Trim

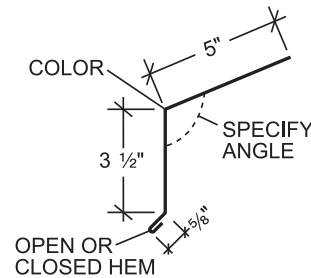

FL-19

Base Trim w/Sheeting Notch

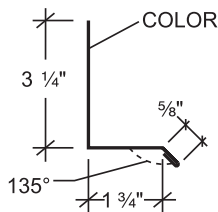

For IL panels please enquire FL-72

Box Hang-On Gutter

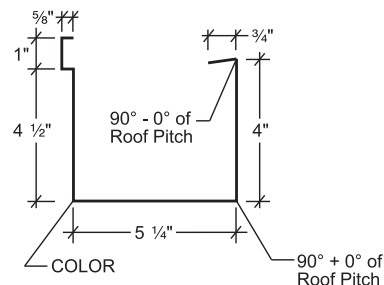

Specify roof slope FL-74D

General Information

FW-120/IL Panel

Product Checklist

Angle Trim

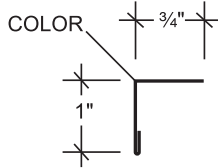

T-5051

Cap Trim

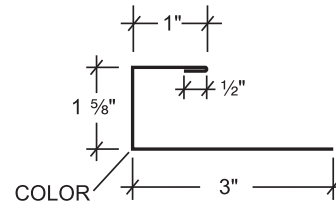

T-5065

Continuous Cleat

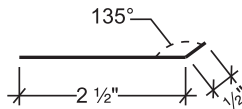

T-5121

Offset Cleat

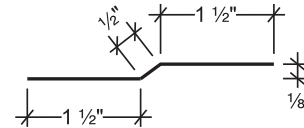

T-5131

Sill/Head Sash

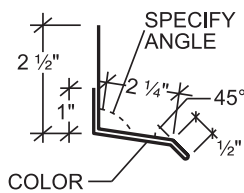

For IL panels please inquire

T-5138

Head/Sill Trim

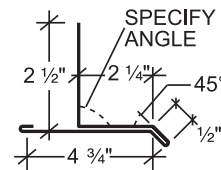

T-5193

Outside Corner Trim

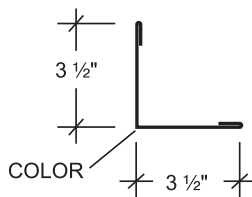

T-5241

Inside Corner Trim

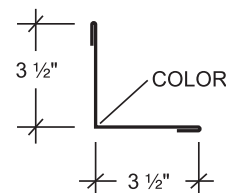

T-5251

FW-120/IL Panel

General Information

Product Checklist

Splice Trim

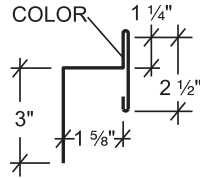

T-5365

Furring Zee

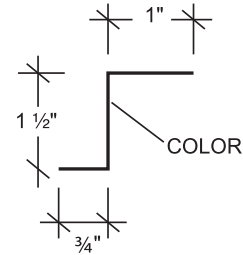

T-6131

Extended Eave Trim

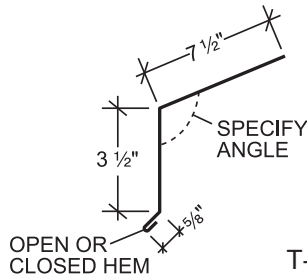

T-5401 10'-2"

T-5402 20'-2"

Sill Trim

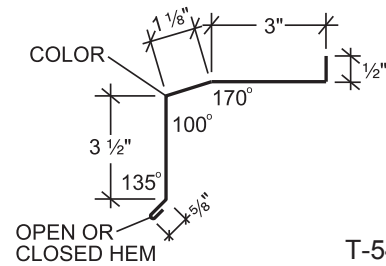

T-5405 10'-2"

T-5406 20'-2"

Wall Splice Trim

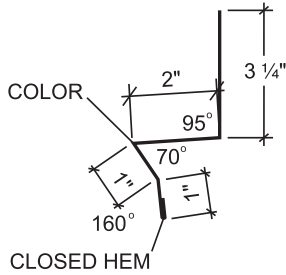

T-5411 10'-2"

For IL panels please inquire

T-5412 20'-2"

Base Trim w/o Sheeting Notch

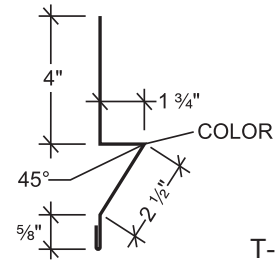

T-5415 10'-2"

For IL panels please inquire

T-5416 20'-2"

Masonry Corner

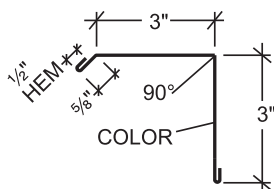

T-5421 10'-2"

T-5422 20'-2"

"Z" Jamb Trim

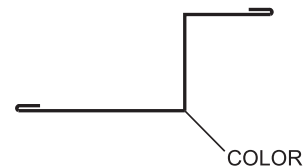

For IL panels please inquire

Special Trim

General Information

FW-120/IL Panel

Preparatory Requirements

1. All details, recommendations, and suggestions in this manual are for general guidelines only, and the actual jobsite conditions may require special treatment and/or changes in this information. Any interpretation and/or change in the details without MBCI's prior consent is not the responsibility of MBCI.
2. MBCI reserves the right to change, modify, or eliminate any and all details, recommendations, and suggestions used in this manual without notice.
3. Suitability of use, or manner of use of any product contained herein is the sole responsibility of the user.
4. Standards of the following societies should be strictly adhered to in design and installation stages of any project using metal panels, light-gauge framing members, and associated accessories:
 - American Iron and Steel Institute (AISI), "Light Gauge Cold-Formed Steel Design Manual".
 - American Society of Testing Materials (ASTM), A-446 Structural Physical Quality for Steel Sheet.
 - National Roofing Contractors Association (NRCA), "The NRCA Construction Details".
 - Light Gauge Structural Institute (LGS), "Light Gauge Structural Steel Framing System Design Handbook".
5. The details in this book are not intended to include **ALL** erection steps, only the relationship of certain MBCI parts to one another. Follow accepted building practices and those approved details in the NRCA sheet metal manual.
6. **NEVER install any material when the quality of the material is in question.**
7. Standard flashing comes in 10'-2" and 20'-2" lengths. Splices are to be 2" minimum and require "field work" in some cases. Special lengths are available on special order.
8. MBCI recommends the use of long life fasteners in exposed applications to compliment the long life coating on the panels and trim. This is necessary for warranty purposes.
9. Panels and trim must not come in contact with dissimilar or harsh materials such as green or wet lumber, lead, copper, or fire retardant chemicals. Contact MBCI for information regarding questionable applications.
10. **Strippable Coating** - MBCI applies a clear protective coating to certain product lines to serve as a buffer to the color finish during fabrication, shipping, and installation. The strippable film should be removed immediately after panel installation.
11. Flat surfaces may display slight waviness. This phenomenon, known as "oil canning", can be caused by steel mill production tolerances, fabrication tolerances and/or framing misalignment, and is not a cause for rejection.
12. Whenever rubber closures are necessary, sealant should be applied to the perimeter of the closure to insure weathertightness.
13. Beginning of installation constitutes acceptance of existing conditions. Verify that all surfaces to be covered are plumb, square, and true to lines and levels.
14. Metal roof and wall systems are not designed to compensate for out of square framing, an uneven framing plane, or poor workmanship. When metal panels are installed over an uneven plane, waviness and oil canning will result.
15. FW panels require a rigid framing system. Since these panels provide no diaphragm capabilities or girt stability, the subframing must be secure and rigid prior to panel installation. Any framing movement after installation will result in deformation of the panel and oil canning.
16. The alignment of all structural steel girts, as well as other steel supports to receive MBCI material must be examined by the installer before commencing installation. Any misalignment shall be reported to the general contractor and erection shall begin only **after** necessary corrections have been made.

CAUTION

Application and design details are for illustration purposes only, and may not be appropriate for all environmental conditions or building designs. Projects should be engineered to conform to all applicable building codes, regulations, and accepted industry practices.

FW-120/IL Panel

General Information

UNLOADING

Upon receiving material, check shipment against shipping list for shortages and damages. The manufacturer will not be responsible for shortages or damages unless they are noted on the shipping list.

Each bundle should be lifted at its center of gravity. Where possible, bundles should remain banded until final placement on roof. If bundles must be opened, they should be retied before lifting.

When lifting bundles with a forklift, forks must be a minimum of five feet apart. Do not transport open bundles. Drive slowly when crossing rough terrain to prevent panel buckling.

CAUTION

Improper unloading and handling of bundles and crates may cause bodily injury or material damage. The manufacturer is not responsible for bodily injuries or material damages during unloading and storage.

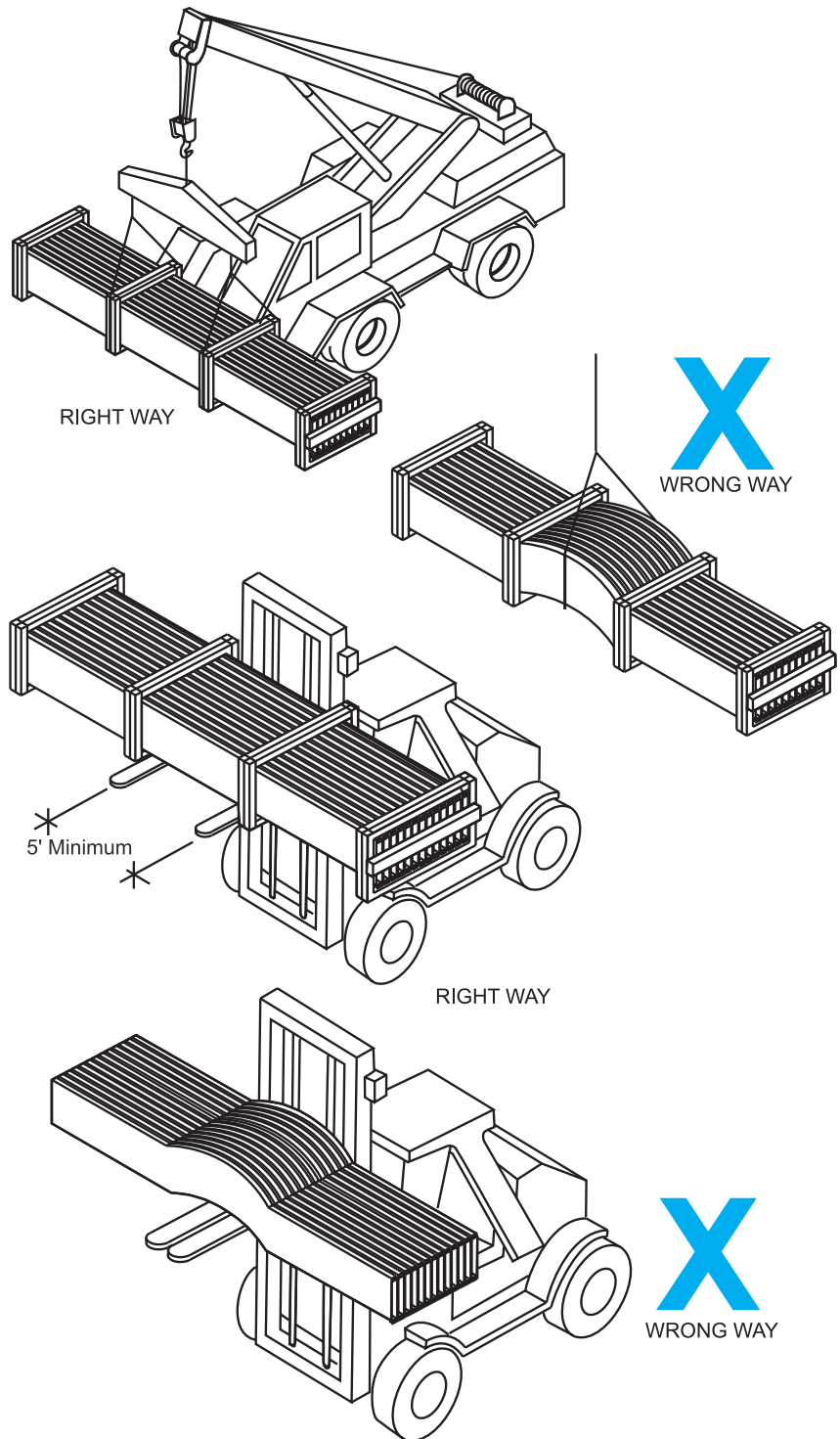

General Information

FW-120 Panel

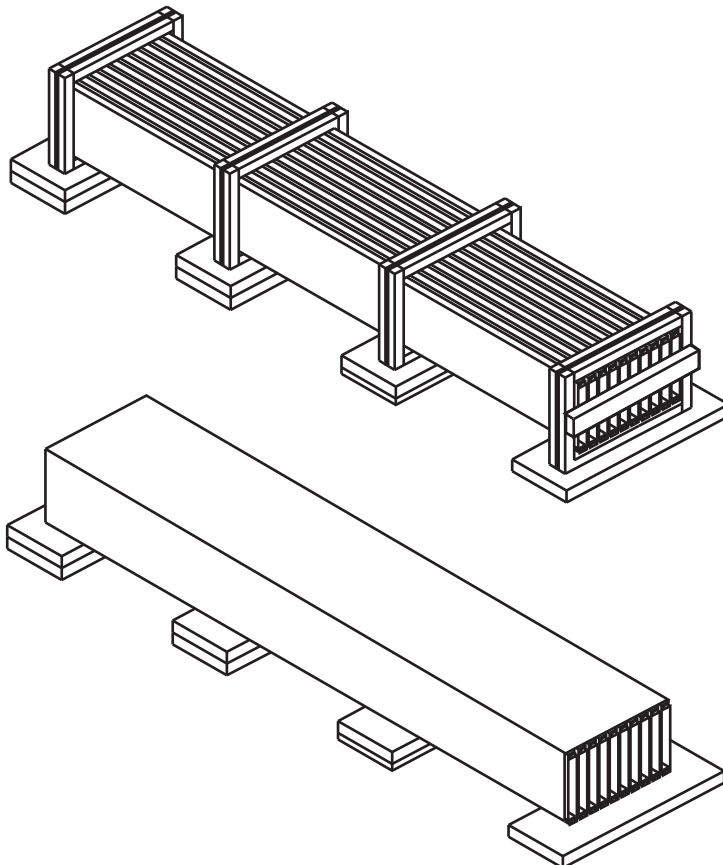
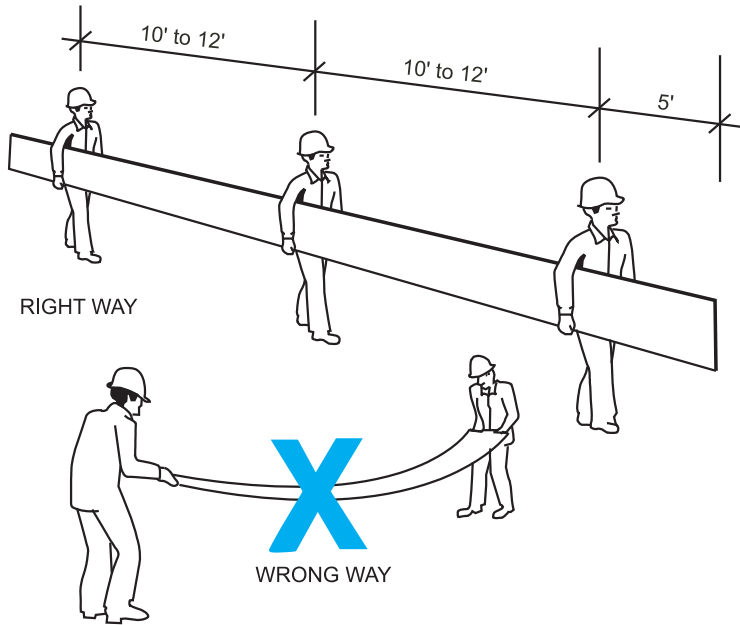

HANDLING / PANEL STORAGE

Standing on one side of the panel, lift it by the seam. If the panel is over 10' long, lift it with two or more people on one side of the panel to prevent buckling.

Do not pick up panel up by the ends.

NOTE

Protective gloves should always be used while handling panels. OSHA safety regulations must be followed at all times.

Store bundled sheets off the ground sufficiently high to allow air circulation beneath bundle and to prevent rising water from entering bundle. Slightly elevate one end of bundle. Prevent rain from entering bundle by covering with a tarp, making provision for air circulation between draped edges of tarp and the ground.

PROLONGED STORAGE OF SHEETS IN A BUNDLE IS NOT RECOMMENDED.

If conditions do not permit immediate erection, extra care should be taken to protect sheets from water damage.

Check to see that moisture has not formed inside the bundles during shipment. If moisture is present, panels should be uncrated and wiped dry, then restacked and loosely covered so that air can circulate between the panels.

FW-120 Panel

Architectural Details

Panel Attachment

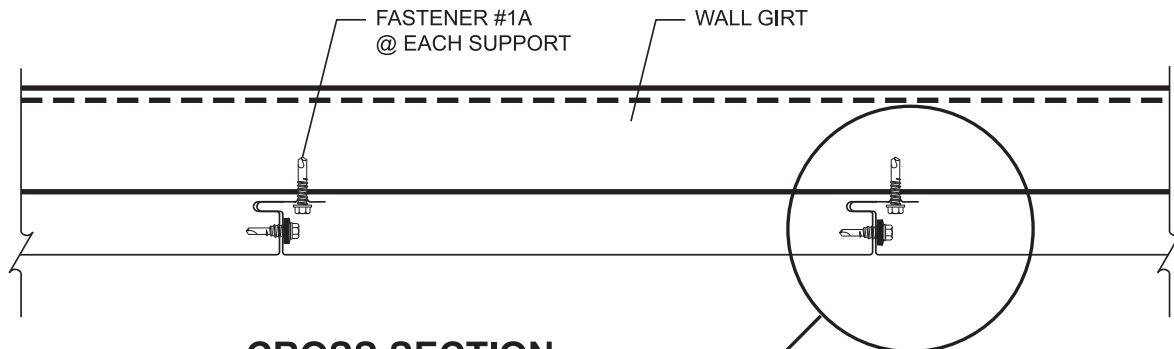

**CROSS SECTION
OF PANEL ATTACHMENT**

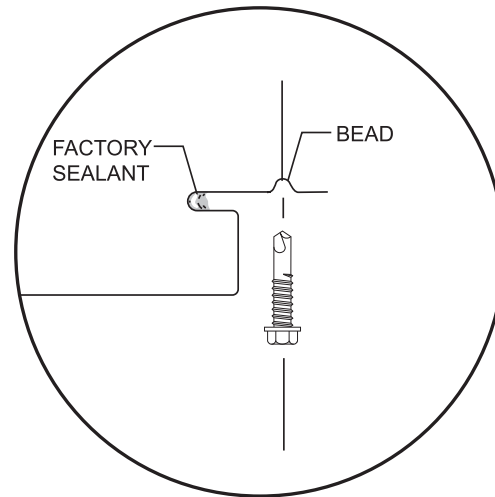
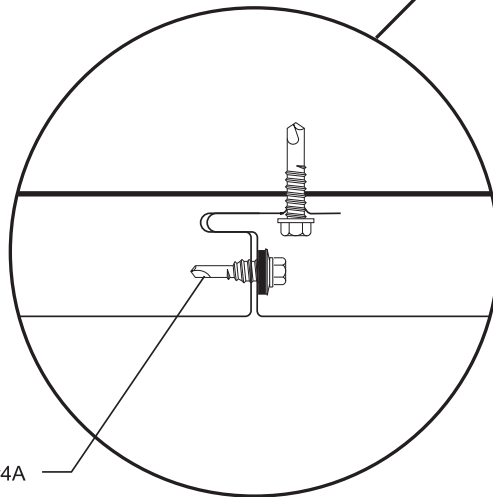

FASTENER LOCATION

Notes:

1. Panels are installed to girts with one 12-14 x 1" S.D. (Fastener #1A) at each girt.
2. Install fasteners in the bead of the female leg of panel.
3. Side-lap fastener may be required based on engineering evaluation of wind loads.

Architectural Details

FW-120 Panel

Typical Wall Splice Attachment

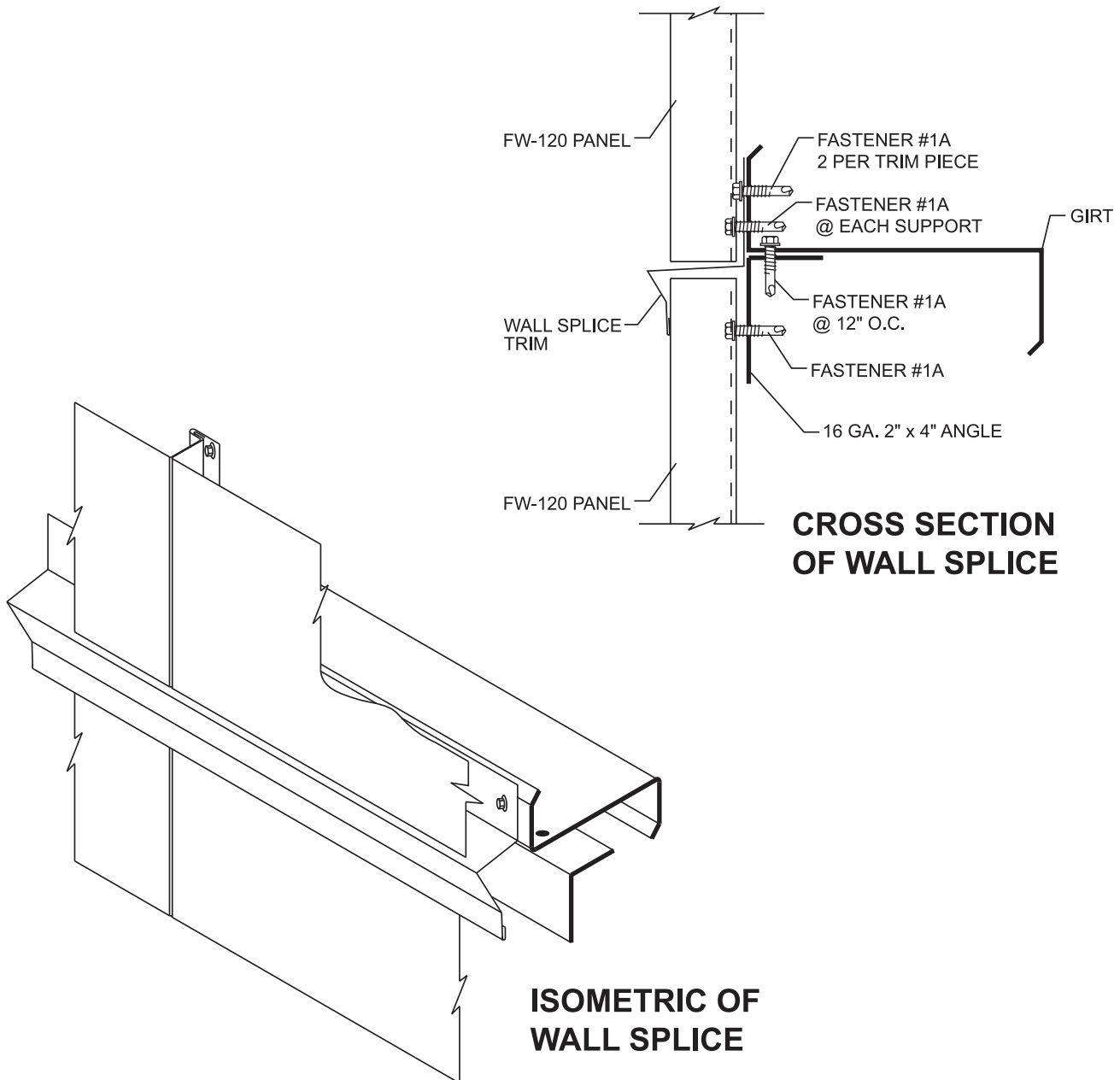

Notes:

1. Fasten 2" x 4" angle to girt with 12-14 x 1" S.D. (Fastener #1A) at 12" O.C..
2. Install lower wall panel with 12-14 x 1" S.D. (Fastener #1A) at each support.
3. Install wall splice trim with two 12-14 x 1" S.D. (Fastener #1A) per trim piece.

FW-120 Panel

Architectural Details

Typical Soffit Details

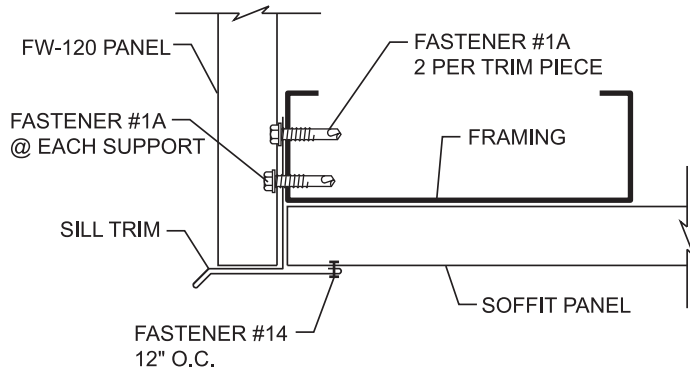

OUTSIDE SOFFIT-WALL DETAIL

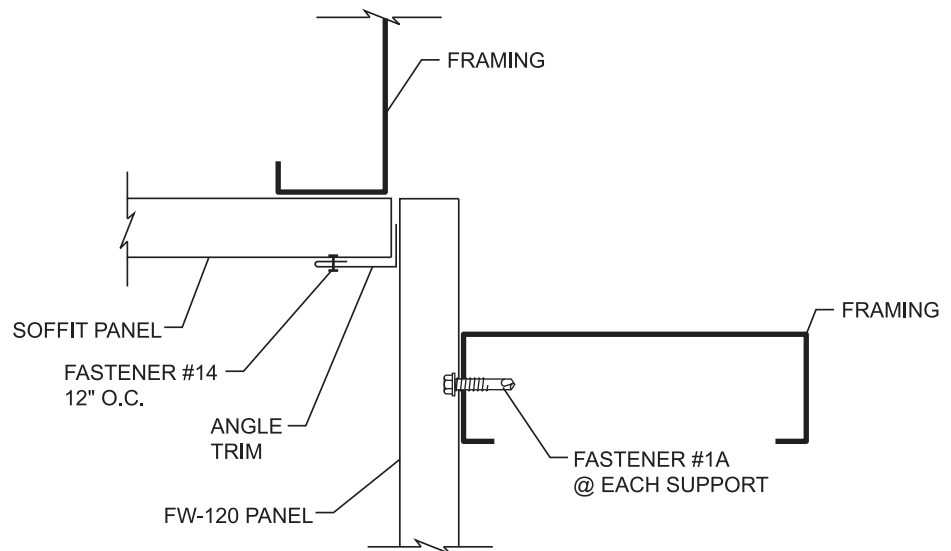

INSIDE SOFFIT-WALL DETAIL

Notes:

1. Install sill trim with two 12-14 x 1" S.D. (Fastener #1A) per trim piece.
2. Install FW-120 wall panels with one 12-14 x 1" S.D. (Fastener #1A) at each support.
3. Pop rivet sill trim and angle trim with 1/8" x 3/16" Pop Rivet (Fastener #14) at 12" O.C.

Architectural Details

FW-120 Panel

Inside and Outside Corners

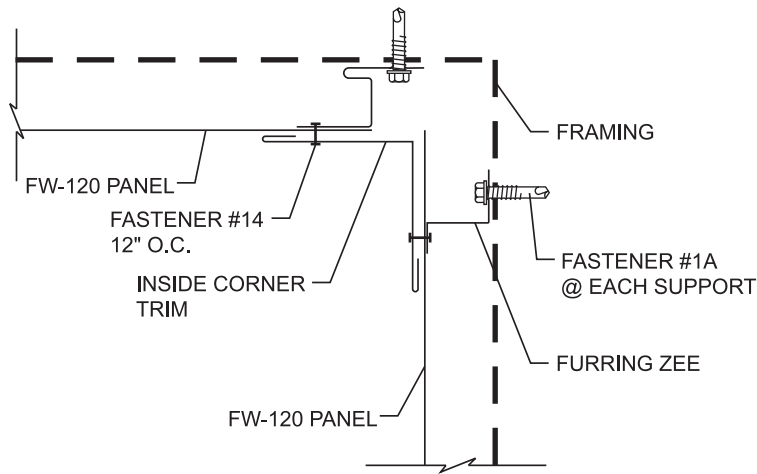

INSIDE CORNER

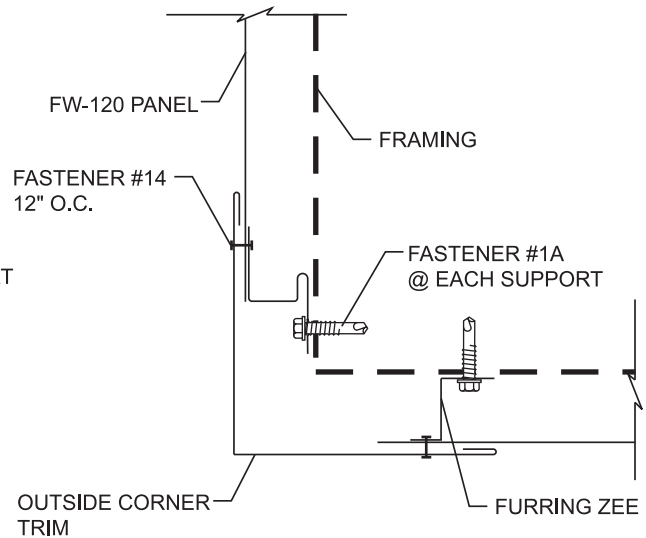

OUTSIDE CORNER

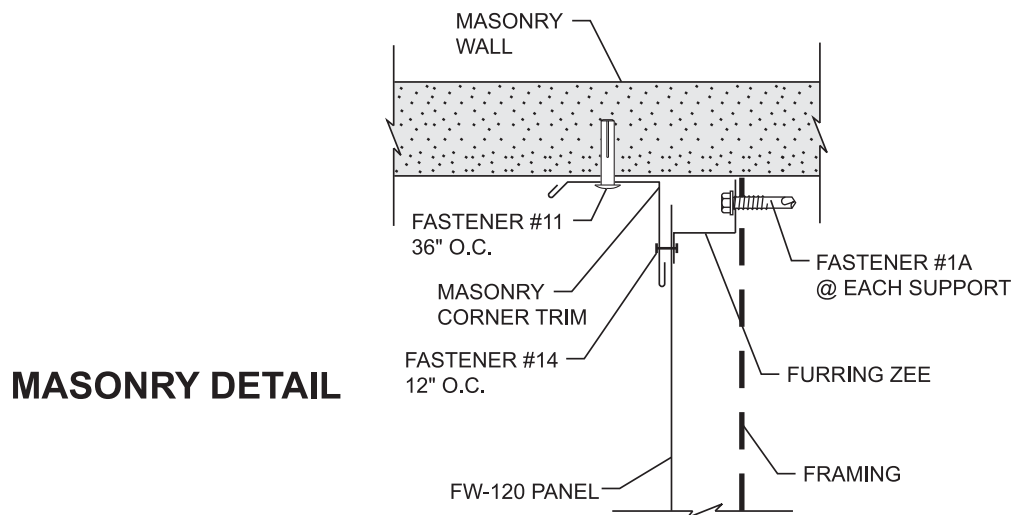

MASONRY DETAIL

Notes:

1. Attach FW-120 panels and furring zee to framing with 12-14 x 1" S.D. (Fastener #1A) at each support.
2. Attach corner trim to FW-120 panel with 1/8" x 3/16" Pop Rivet (Fastener #14) at 12" O.C.

FW-120 Panel Architectural Details

Typical Base Details

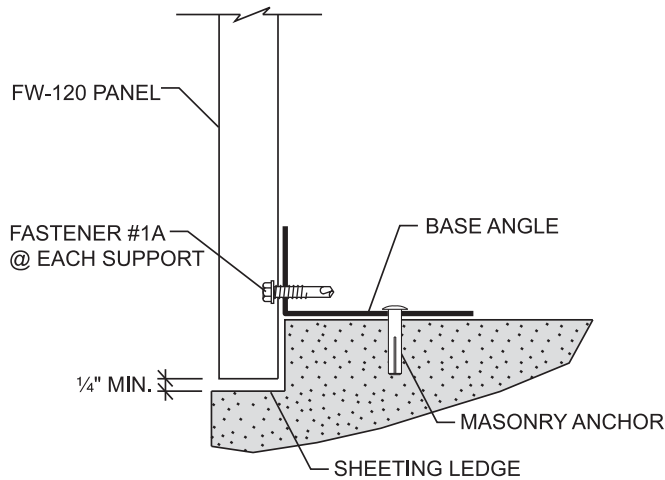

**BASE DETAIL
WITH SHEETING NOTCH**

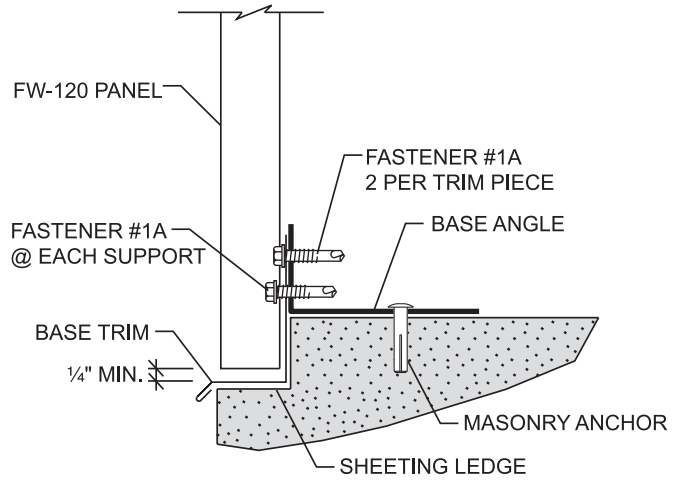

**ALTERNATE DETAIL
WITH SHEETING NOTCH**

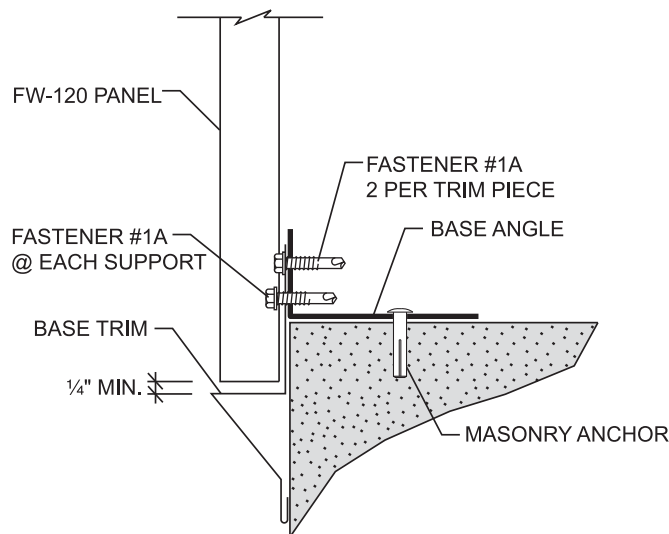

**BASE DETAIL
WITHOUT SHEETING NOTCH**

Notes:

1. Attach FW-120 panels to base angle with 12-14 x 1" S.D. (Fastener #1A) at each connection.
2. Should base trim be desired, temporarily attach trim to base angle with two 12-14 x 1" S.D. (Fastener #1A) per each trim piece.

Architectural Details

FW-120 Panel

Typical Details at Overhead Doors

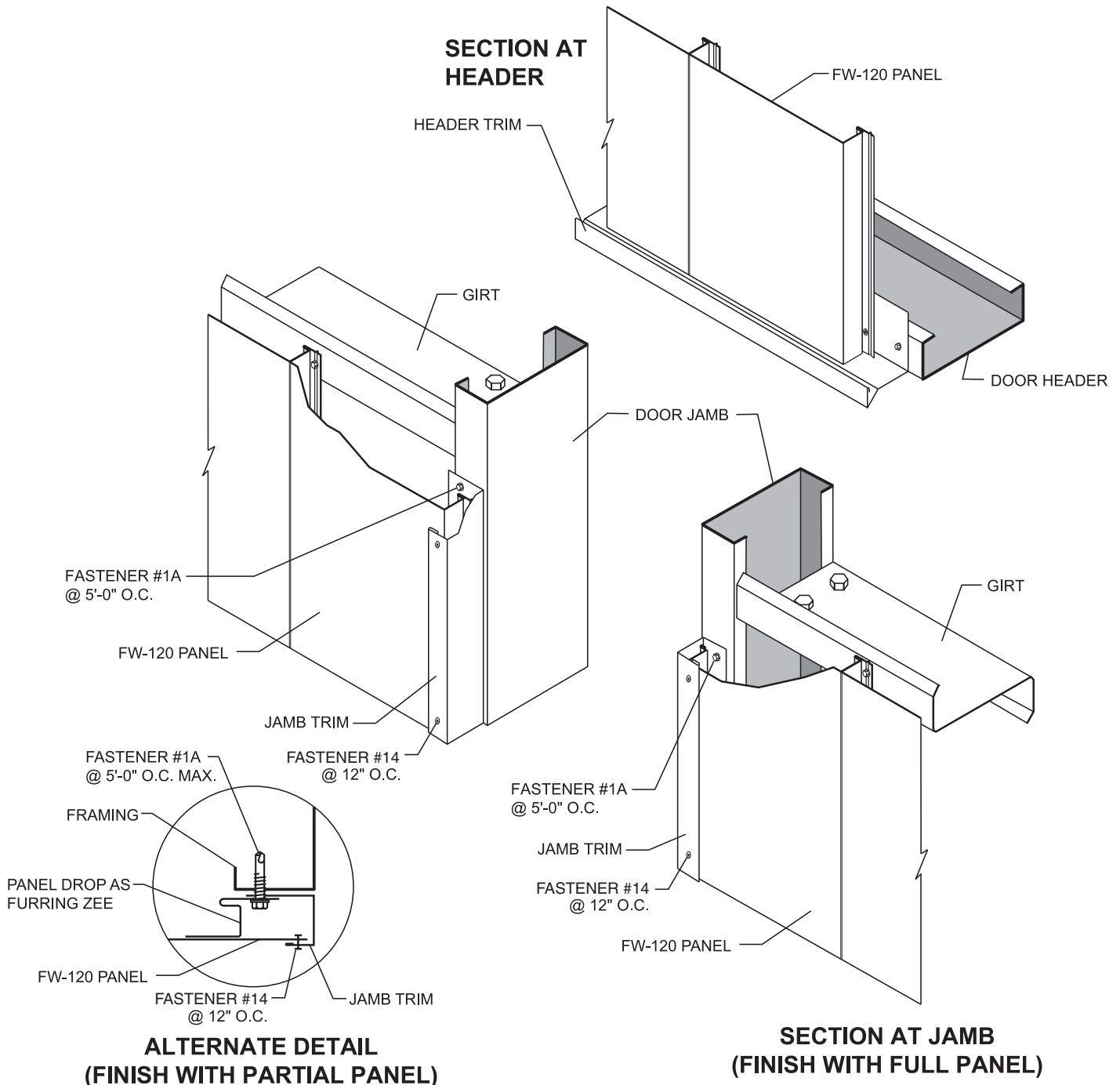

Notes:

1. Attach jamb trim to framing with 12-14 x 1" S.D. (Fastener #1A) at 5'-0" O.C.
2. Attach header trim to framing with two 12-14 x 1" S.D. (Fastener #1A) per trim piece.
3. Attach jamb trim to FW-120 panel with 1/8" x 3/16" Pop Rivet (Fastener #14) at 12" O.C.
4. Seal the bottom of all panels above the overhead door inside the head trim with urethane sealant.

FW-120 Panel Architectural Details

Typical Details at Walk Doors

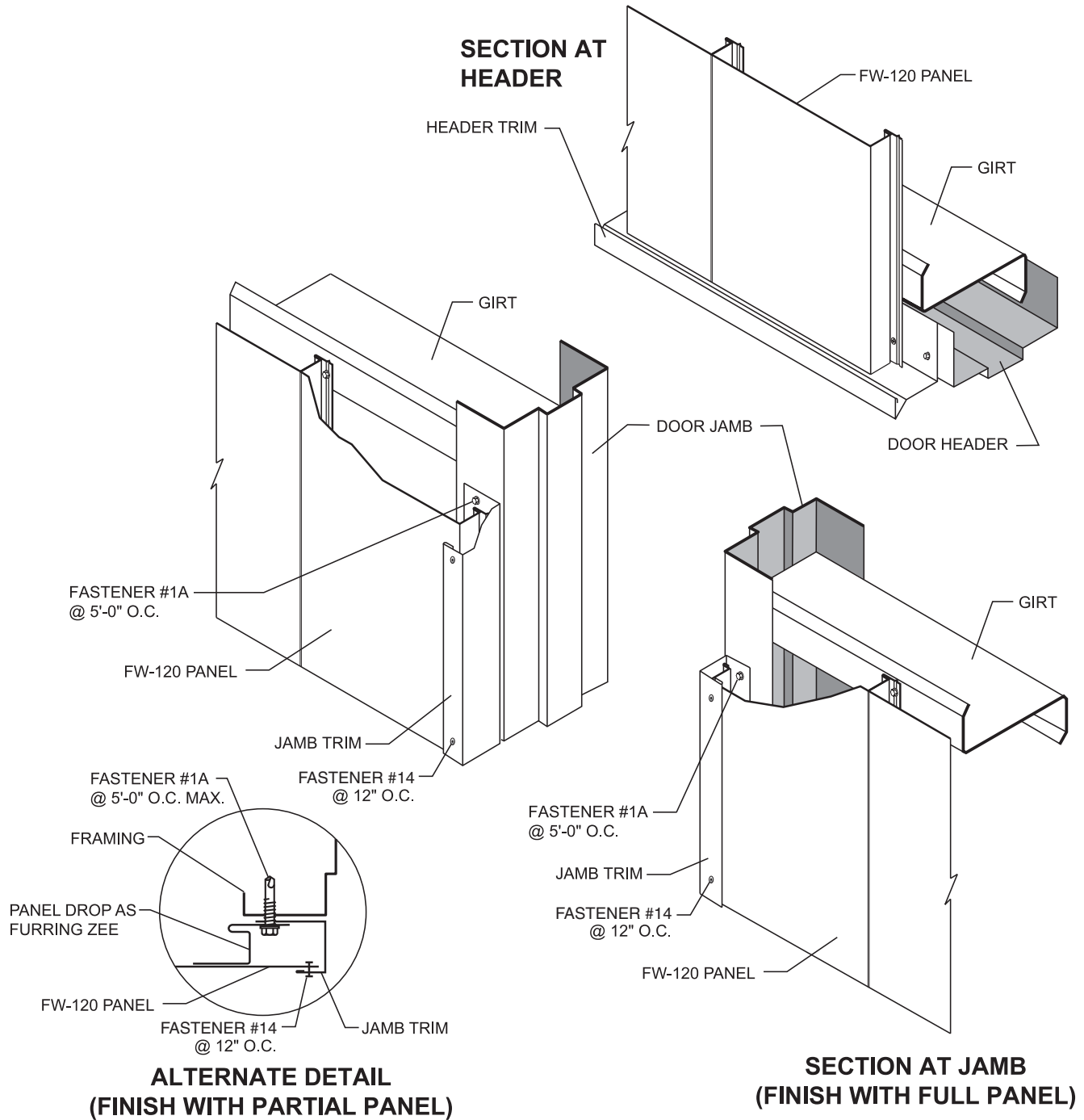

Notes:

1. Attach jamb trim to framing with 12-14 x 1" S.D. (Fastener #1A) at 5'-0" O.C.
2. Attach header trim to framing with two 12-14 x 1" S.D. (Fastener #1A) per trim piece.
3. Attach jamb trim to FW-120 panel with 1/8" x 3/16" Pop Rivet (Fastener #14) at 12" O.C.
4. Seal the bottom of all panels above the walk door inside the head trim with urethane sealant.

Architectural Details

FW-120 Panel

Typical Details at Windows

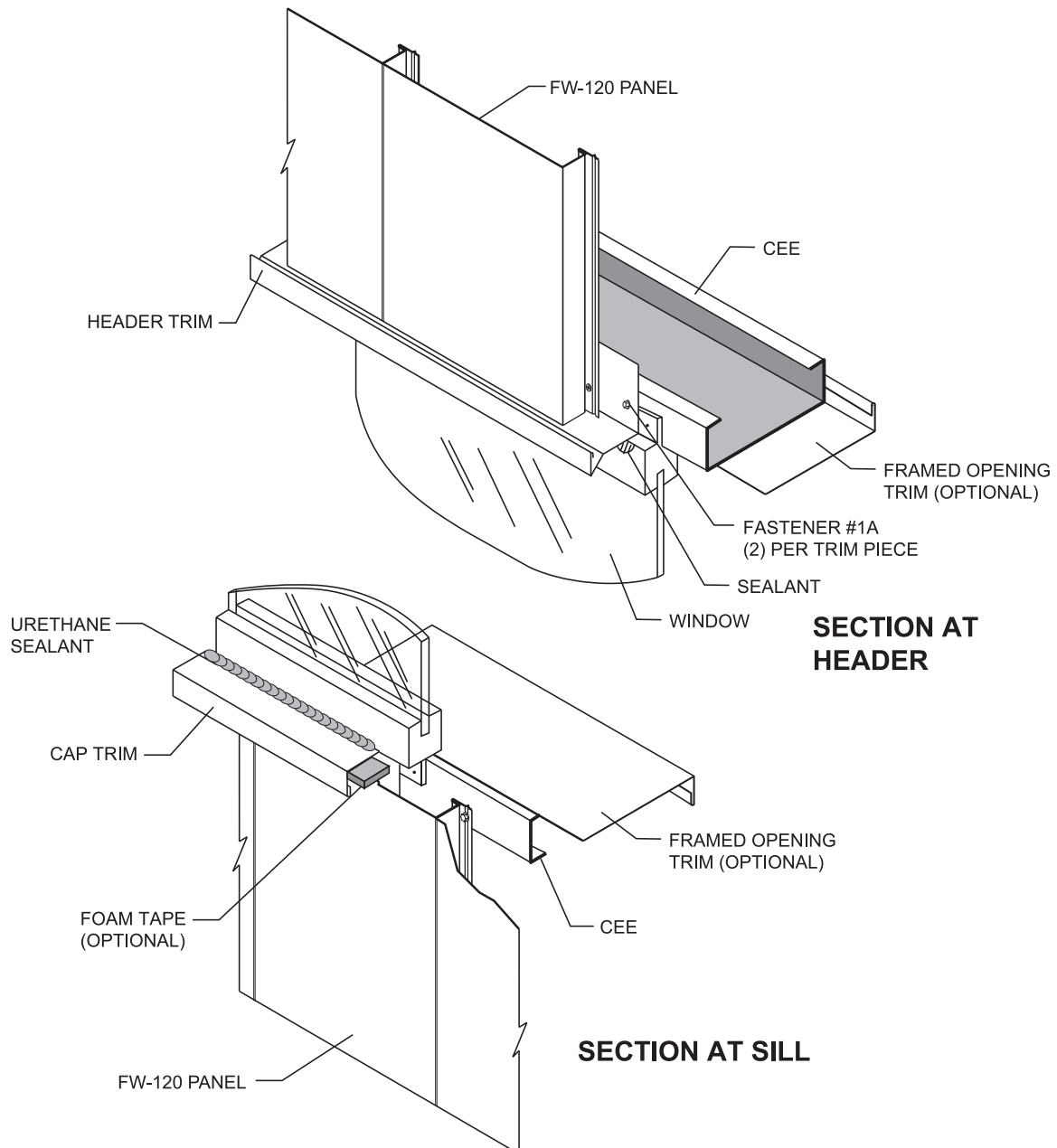

Notes:

1. Attach header or cap trim with two 12-14 x 1" S.D. (Fastener #1A) per trim piece.
2. Install header trim at top and cap trim at bottom of window. Header trim and cap trim should be the width of the framed opening plus 4" in length.
3. Attach FW-120 panels to framing with 12-14 x 1" S.D. (Fastener #1A) at each support.
4. Details shown utilize a straight fin window.
5. Foam tape can be applied to underside of cap trim to provide an airtight seal.
6. Seal window frame to trim on all four sides with urethane sealant.

FW-120 Panel Architectural Details

Typical Details at Windows (Cont.)

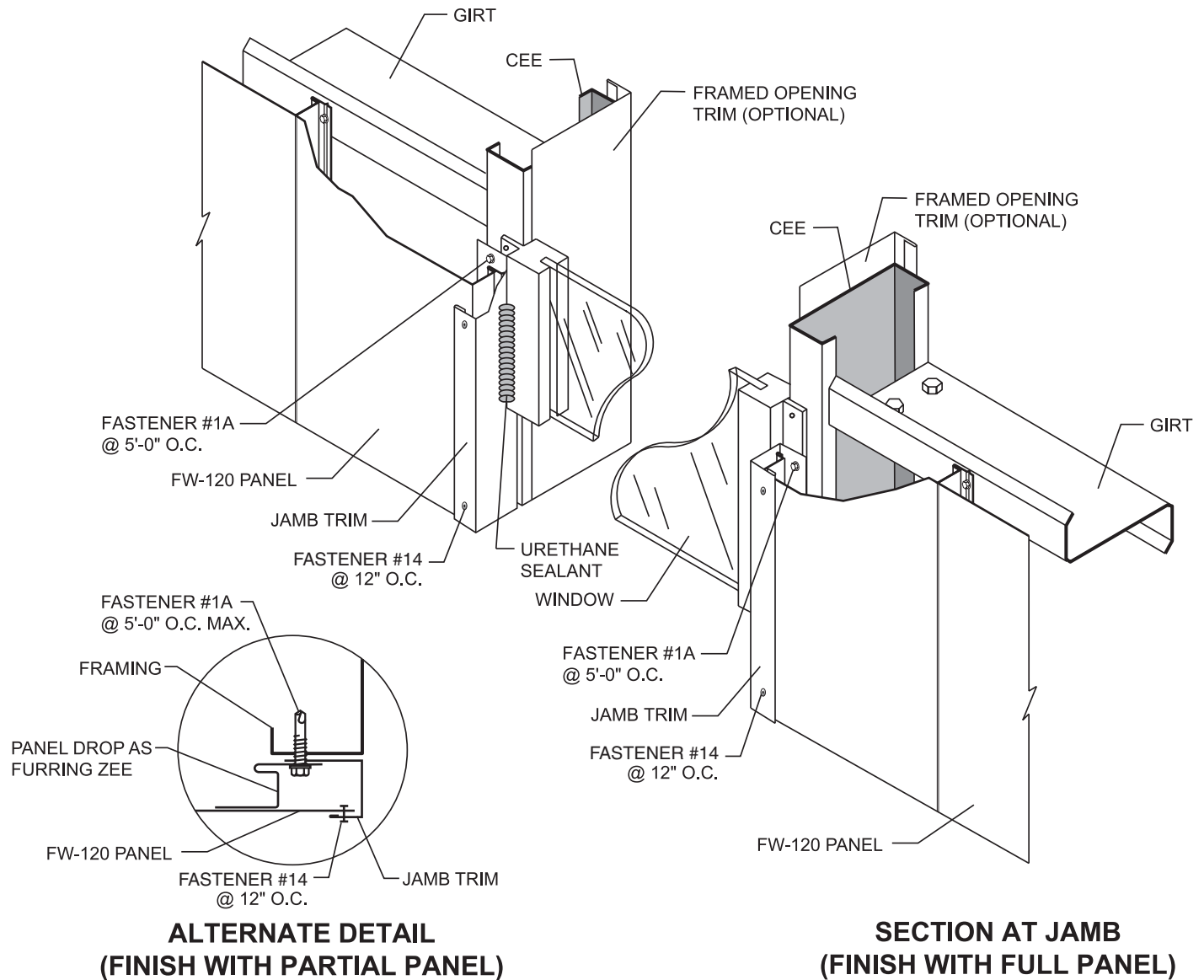

Notes:

1. Install jamb trim at both sides of window. Jamb trim will fit inside of header trim and cap trim. Top of jamb trim must be mitered to fit slope of header trim.
2. Seal window frame to trim on all four sides with urethane sealant.

Architectural Details

FW-120 Panel

Typical Jamb/Head Intersection Detail

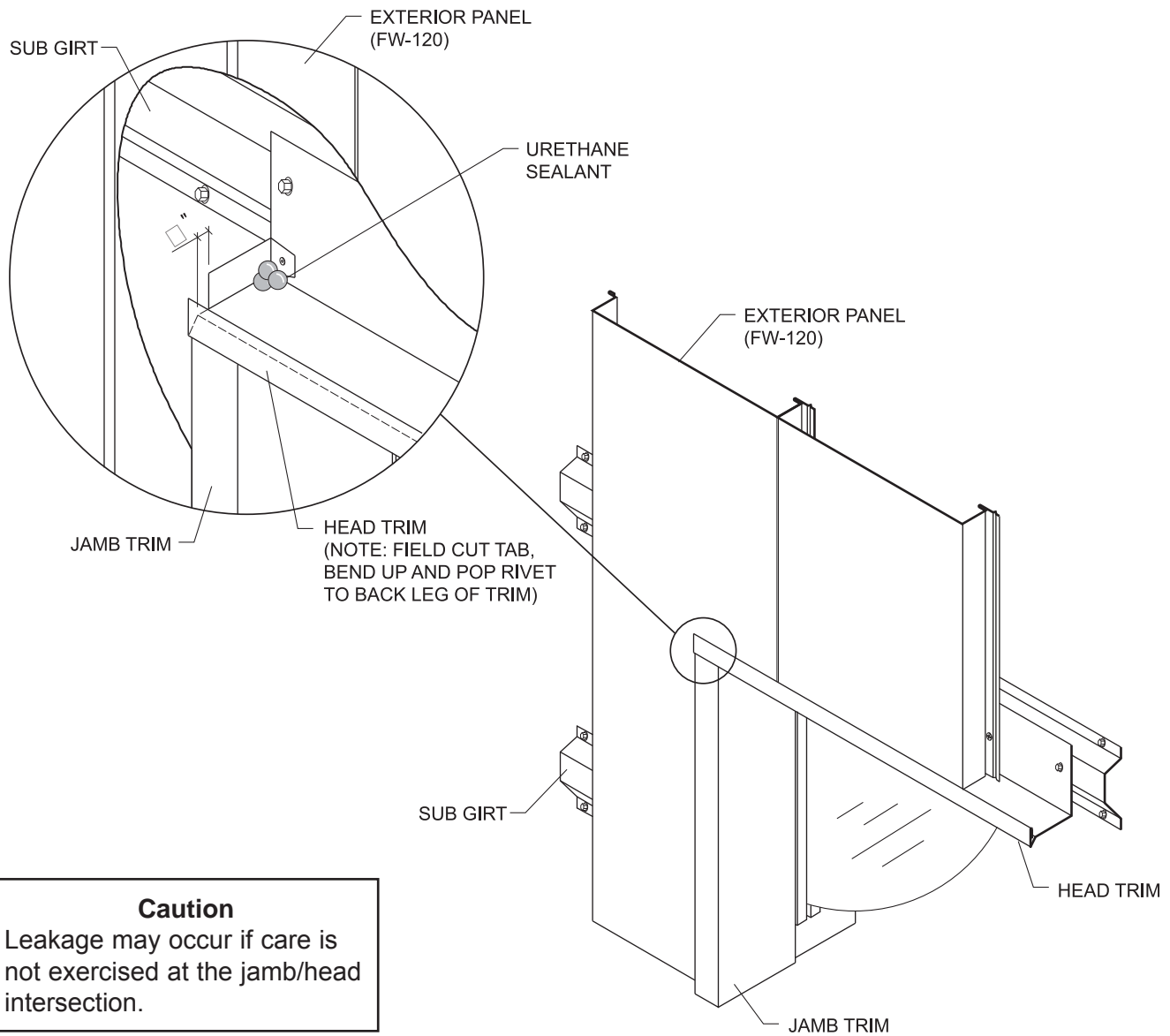

Caution

Leakage may occur if care is not exercised at the jamb/head intersection.

Houston, TX 877-713-6224
Adel, GA 888-446-6224
Atlanta, GA 877-512-6224
Atwater, CA 800-829-9324
Dallas, TX 800-653-6224

Indianapolis, IN 800-735-6224
Lubbock, TX 800-758-6224
Memphis, TN 800-206-6224
Oklahoma City, OK 800-597-6224
Omaha, NE 800-458-6224

Phoenix, AZ 888-533-6224
Richmond, VA 800-729-6224
Rome, NY 800-559-6224
Salt Lake City, UT 800-874-2404
San Antonio, TX 800-598-6224



FW-120 Panel Architectural Details

Typical Panel Attachment Detail

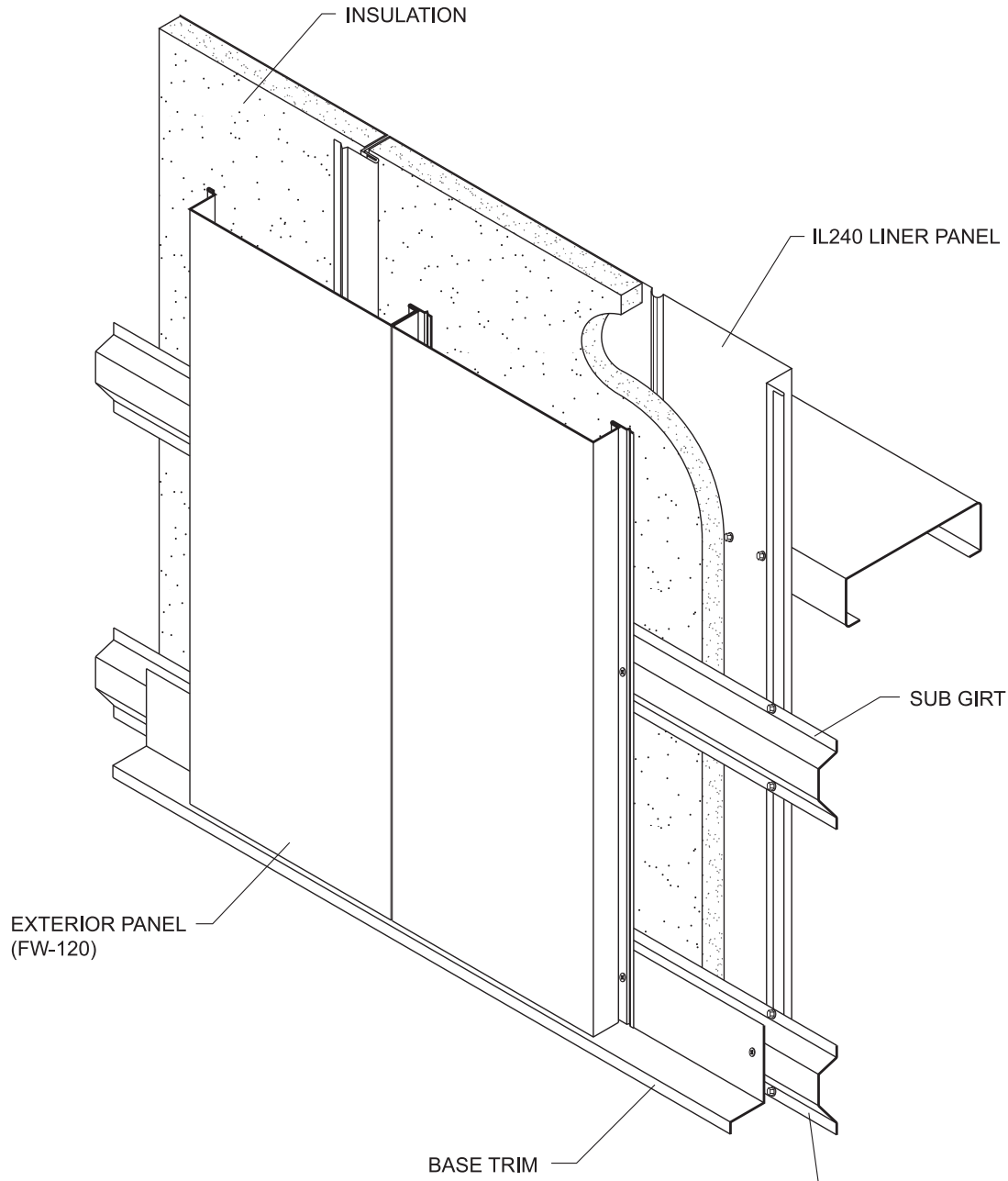

Composite Wall

FW-120/IL Panel

Inside Corner Detail

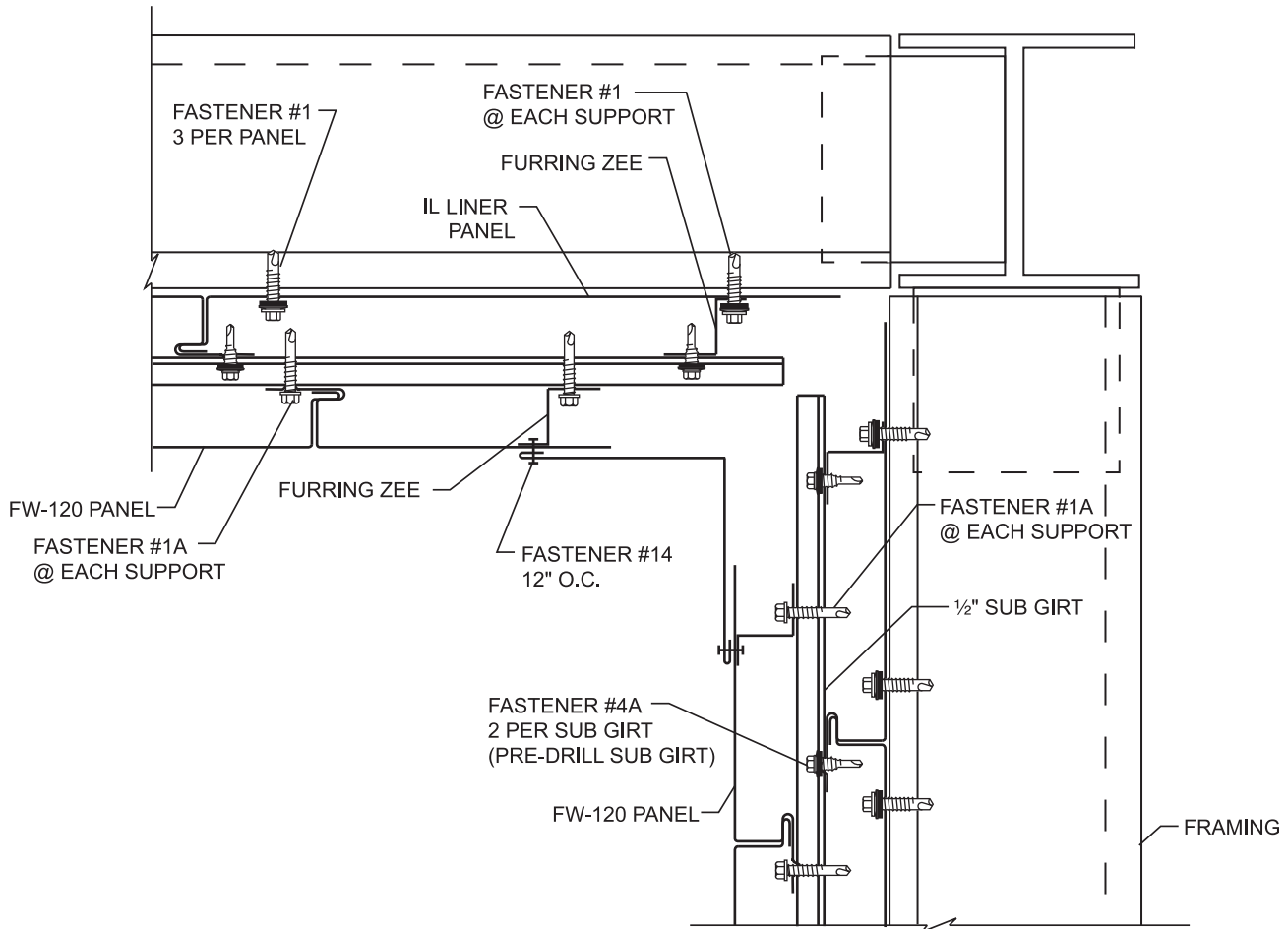

Notes:

1. Attach liner panels to framing with three ¼"-14 x 1" S.D. (Fastener #1) at each support.
2. Attach furring zee to framing with ¼"-14 x 1" S.D. (Fastener #1) at each support.
3. Attach ½" sub girt to liner panel with two ¼"-14 x 7/8" Lap Tek[®] S.D. (Fastener #4A) at each connection. (Pre-drill sub girt.)
4. Attach FW-120 panel and furring zee to sub girt with 12-14 X 1" S.D. (Fastener #1A) at each support.
5. Attach corner trim to FW-120 panel with ⅛" x 3/16" Pop Rivet (Fastener #14) at 12" O.C.

FW-120/IL Panel

Composite Wall

Outside Corner Detail

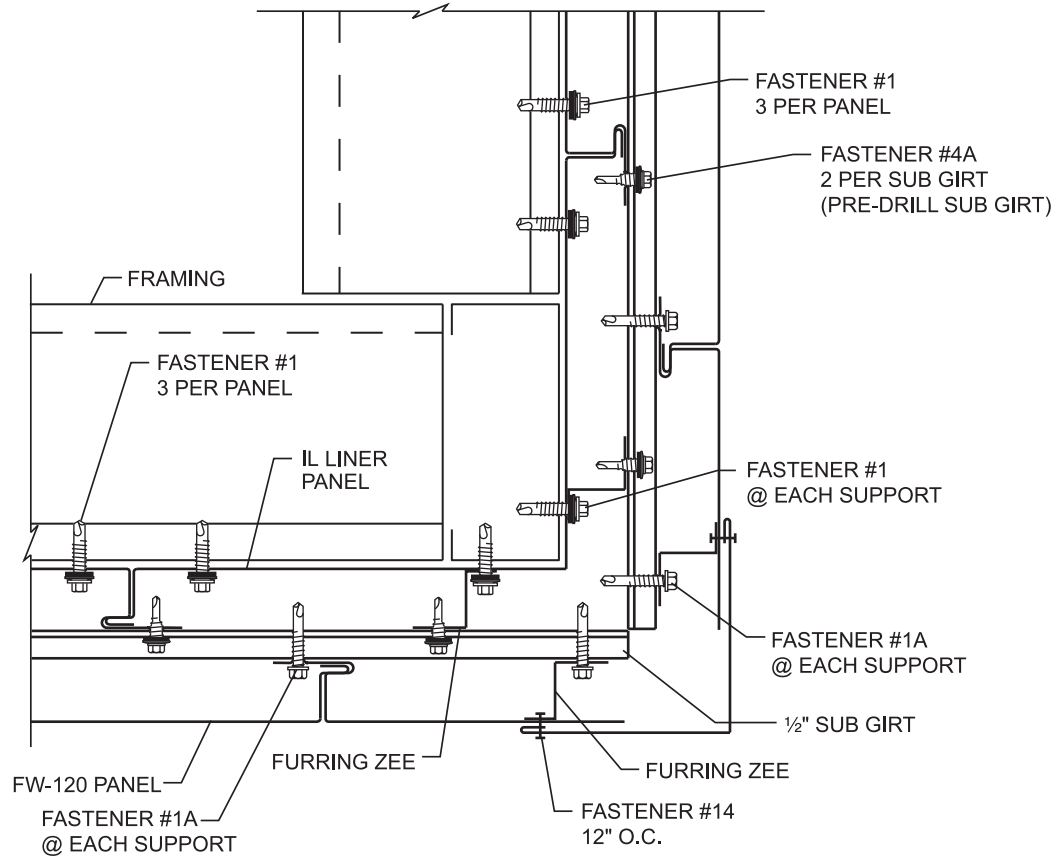

Notes:

1. Attach liner panels to framing with three 1/4"-14 x 1" S.D. (Fastener #1) at each support.
2. Attach furring zee to framing with 1/4"-14 x 1" S.D. (Fastener #1) at each support.
3. Attach 1/2" sub girt to liner panel with two 1/4"-14 x 7/8" Lap Tek[®] S.D. (Fastener #4A) at each connection. (Pre-drill sub girt.)
4. Attach FW-120 panel and furring zee to sub girt with 12-14 X 1" S.D. (Fastener #1A) at each support.
5. Attach corner trim to FW-120 panel with 1/8" x 3/16" Pop Rivet (Fastener #14) at 12" O.C.

Composite Wall System

FW-120/IL Panel

Typical Base Details

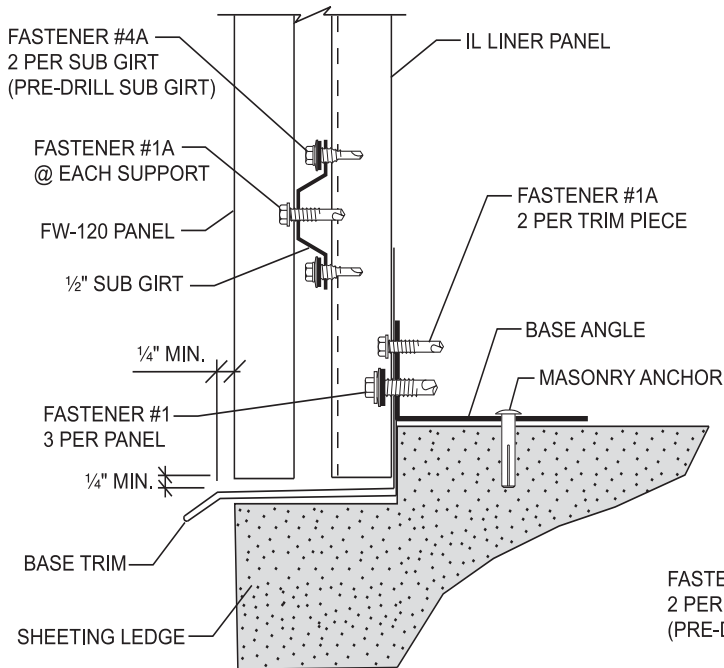

**BASE DETAIL
WITH SHEETING NOTCH**

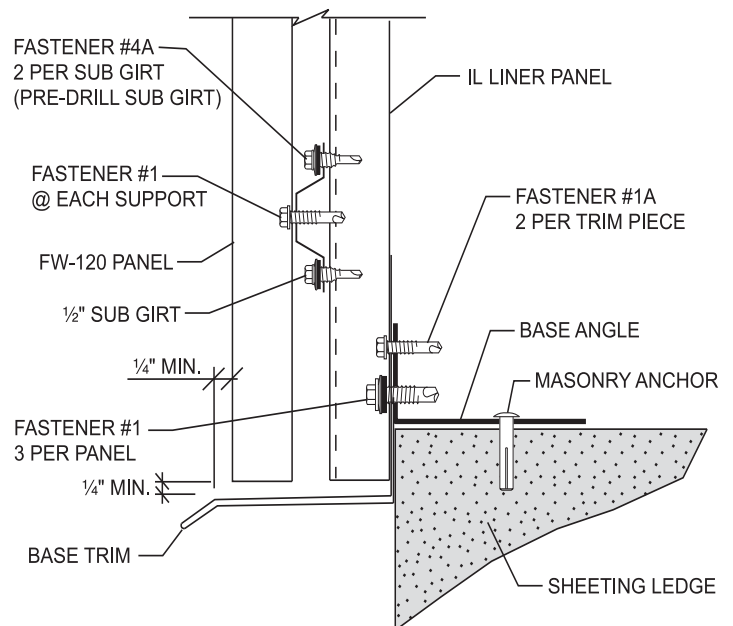

**BASE DETAIL
WITHOUT SHEETING NOTCH**

Notes:

1. Attach base trim to base angle with two 12-14 x 1" S.D. (Fastener #1A) per trim piece.
2. Attach liner panels to base angle with three 1/4"-14 x 1" S.D. (Fastener #1).
3. Attach 1/2" sub girt to liner panel with Two 1/4"-14 x 7/8" Lap Tek® S.D. (Fastener #4A) at each connection. (Pre-drill sub girt.)
4. Attach FW-120 panel and furring zee to sub girt with 12-14 X 1" S.D. (Fastener #1A) at each support.

FW-120/IL Panel

Composite Wall System

Typical Window/Door Jamb Details

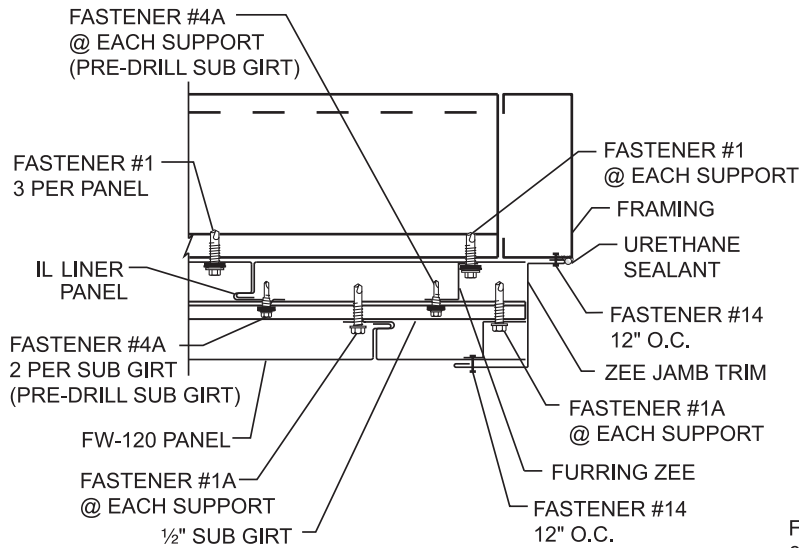

JAMB DETAIL WITH ZEE JAMB TRIM

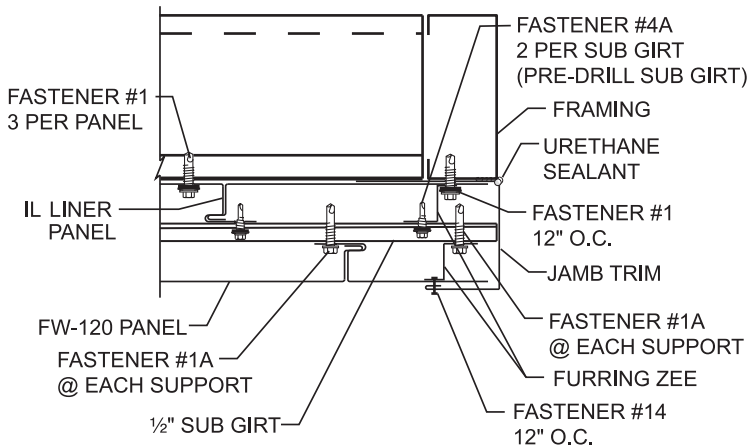

JAMB DETAIL WITH CEE JAMB TRIM

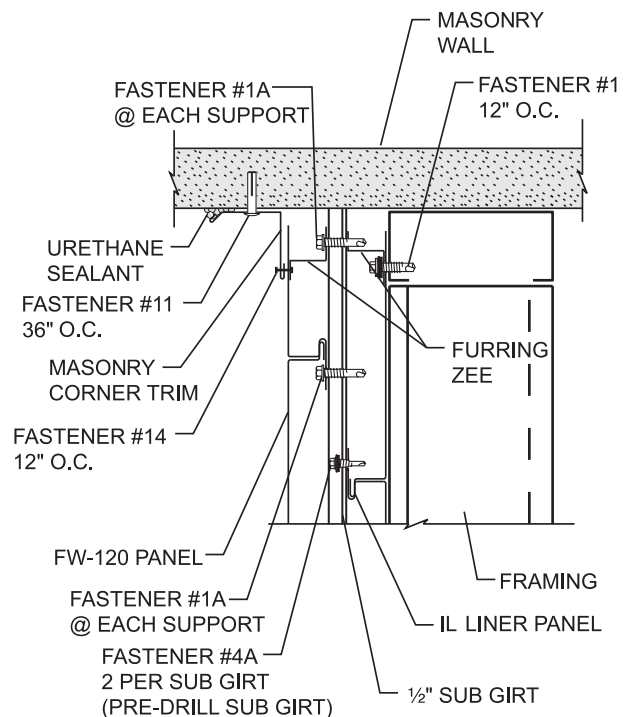

MASONRY DETAIL

Notes:

1. Attach liner panels to framing with three 1/4"-14 x 1" S.D. (Fastener #1) at each support.
2. Attach furring zee to framing with 1/4"-14 x 1" S.D. (Fastener #1) at each support.
3. Attach 1/2" sub girt to liner panel with two 1/4"-14 x 7/8" Lap Tek® S.D. (Fastener #4A) at each connection. (Pre-drill sub girt.)
4. Attach FW-120 panel and furring zee to sub girt with 12-14 X 1" S.D. (Fastener #1A) at each support.
5. Attach jamb trim to FW-120 panel with 1/8" x 3/16" Pop Rivet (Fastener #14) at 12" O.C.

Composite Wall System

FW-120/IL Panel

Typical Window Head/Sill Details

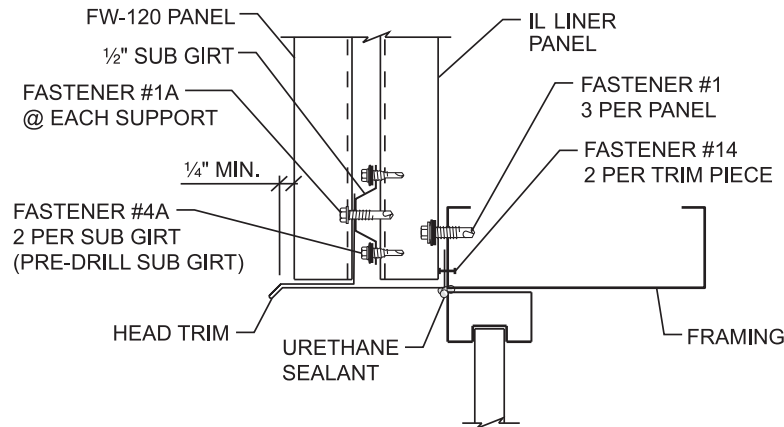

WINDOW HEAD DETAIL

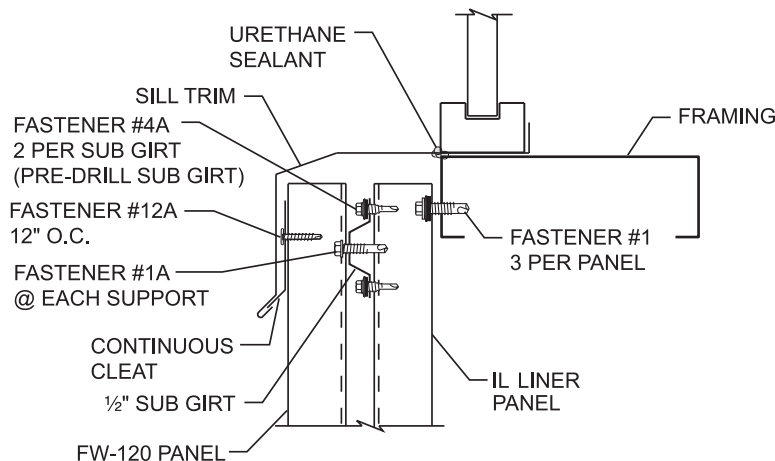

WINDOW SILL DETAIL

Notes:

1. Attach liner panels to framing with three 1/4"-14 x 1" S.D. (Fastener #1) at each support.
2. Attach 1/2" sub girt to liner panel with two 1/4"-14 x 7/8" Lap Tek[®] S.D. (Fastener #4A) at each connection. (Pre-drill sub girt.)
3. Attach FW-120 panels to sub girt with 12-14 X 1" S.D. (Fastener #1A) at each support.
4. Attach continuous cleat to FW-120 panel with 12 x 1" pancake head S.D. (Fastener #12A) at 12" O.C.
5. Hook sill trim onto continuous cleat and secure trim to structure.
6. Seal window frame to trim on all four sides with urethane sealant.

FW-120/IL Panel

Composite Wall System

Typical Jamb/Head Intersection Detail

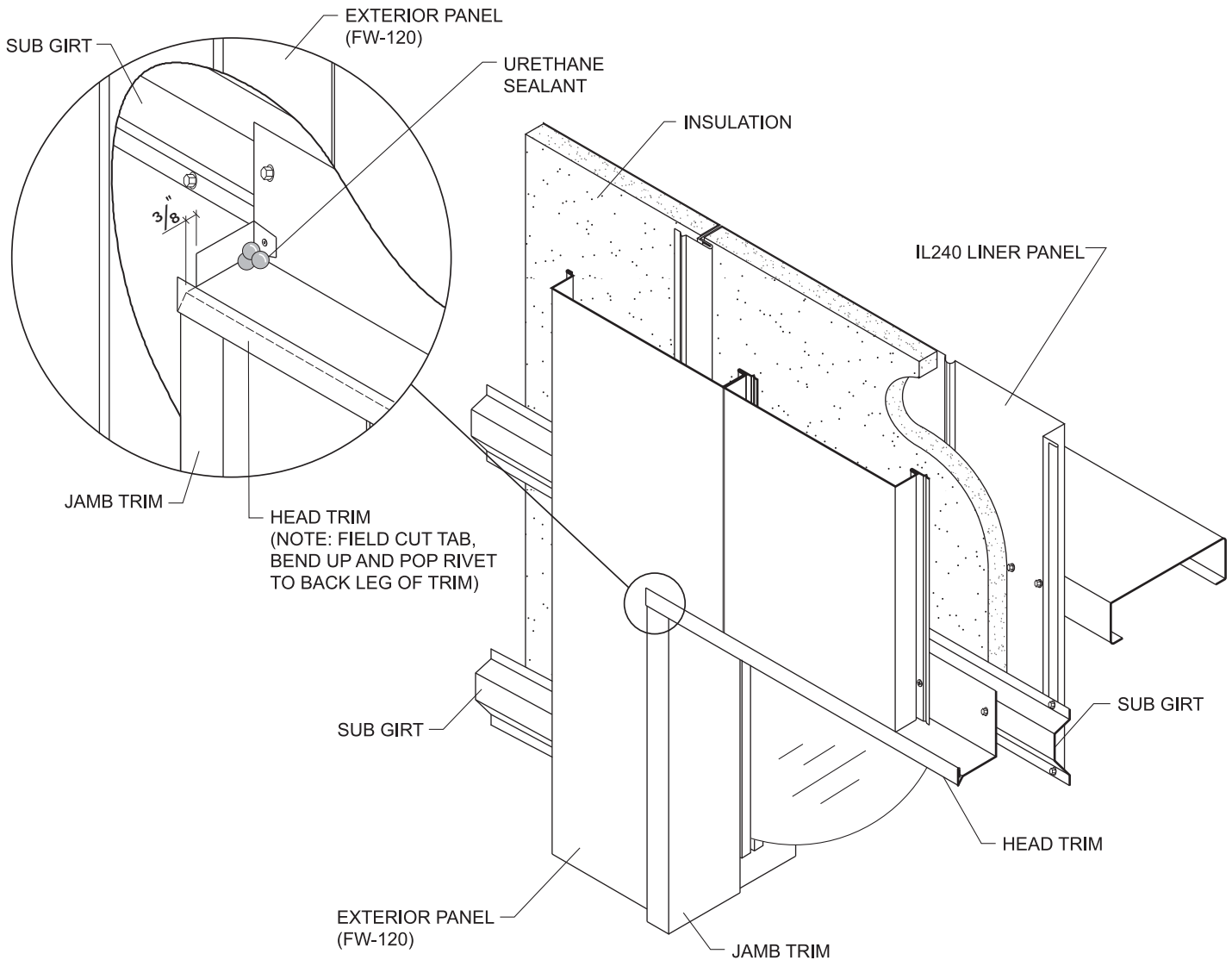

Caution

Leakage may occur if care is not exercised at the jamb/head intersection.



For current information, visit our Website at www.mbc.com.

Descriptions and specifications contained herein were in effect at the time this publication was approved for printing. In a continuing effort to refine and improve products, MBCI reserves the right to discontinue products at any time or change specifications and/or designs without incurring obligation. To ensure you have the latest information available, please inquire or visit our website at www.mbc.com. Application details are for illustration purposes only and may not be appropriate for all environmental conditions, building designs or panel profiles. Projects should be designed to conform to applicable building codes, regulations and accepted industry practices. If there is a conflict between this manual and project erection drawings, the erection drawings will take precedence.

Houston, TX
14031 West Hardy
P.O. Box 38217
Houston, TX 77238
877-713-6224

Dallas, TX
1804 Jack McKay Blvd.
P.O. Box 1210
Ennis, TX 75120
800-653-6224

Oklahoma City, OK
7000 S. Eastern Avenue
P.O. Box 95998
Oklahoma City, OK 73143
800-597-6224

Rome, NY
6168 State Route 233
P.O. Box 4141
Rome, NY 13442
800-559-6224

Adel, GA
1601 Rogers Road
P.O. Box 1107
Adel, GA 31620
888-446-6224

Indianapolis, IN
1780 McCall Drive
P.O. Box 657
Shelbyville, IN 46176
800-735-6224

Omaha, NE
1011 Ellison Avenue
Omaha, NE 68119
800-458-6224

Salt Lake City, UT
1155 West 2300 North
P.O. Box 16027
Salt Lake City, UT 84116
800-874-2404

Atlanta, GA
2280 Monier Avenue
P.O. Box 44729
Atlanta, GA 30336
877-512-6224

Lubbock, TX
5711 East FM-40
P.O. Box 10133
Lubbock, TX 79408
800-758-6224

Phoenix, AZ
660 South 91st Avenue
P.O. Box 739
Tolleson, AZ 85353
888-533-6224

San Antonio, TX
8677 I-10 East
P.O. Box 69
Converse, TX 78109
800-598-6224

Atwater, CA
550 Industry Way
P.O. Box 793
Atwater, CA 95301
800-829-9324

Memphis, TN
300 Highway 51 North
P.O. Box 366
Hernando, MS 38632
800-206-6224

Richmond, VA
801 South Avenue
P.O. Box 239
Colonial Heights, VA 23834
800-729-6224

