

X304012-1

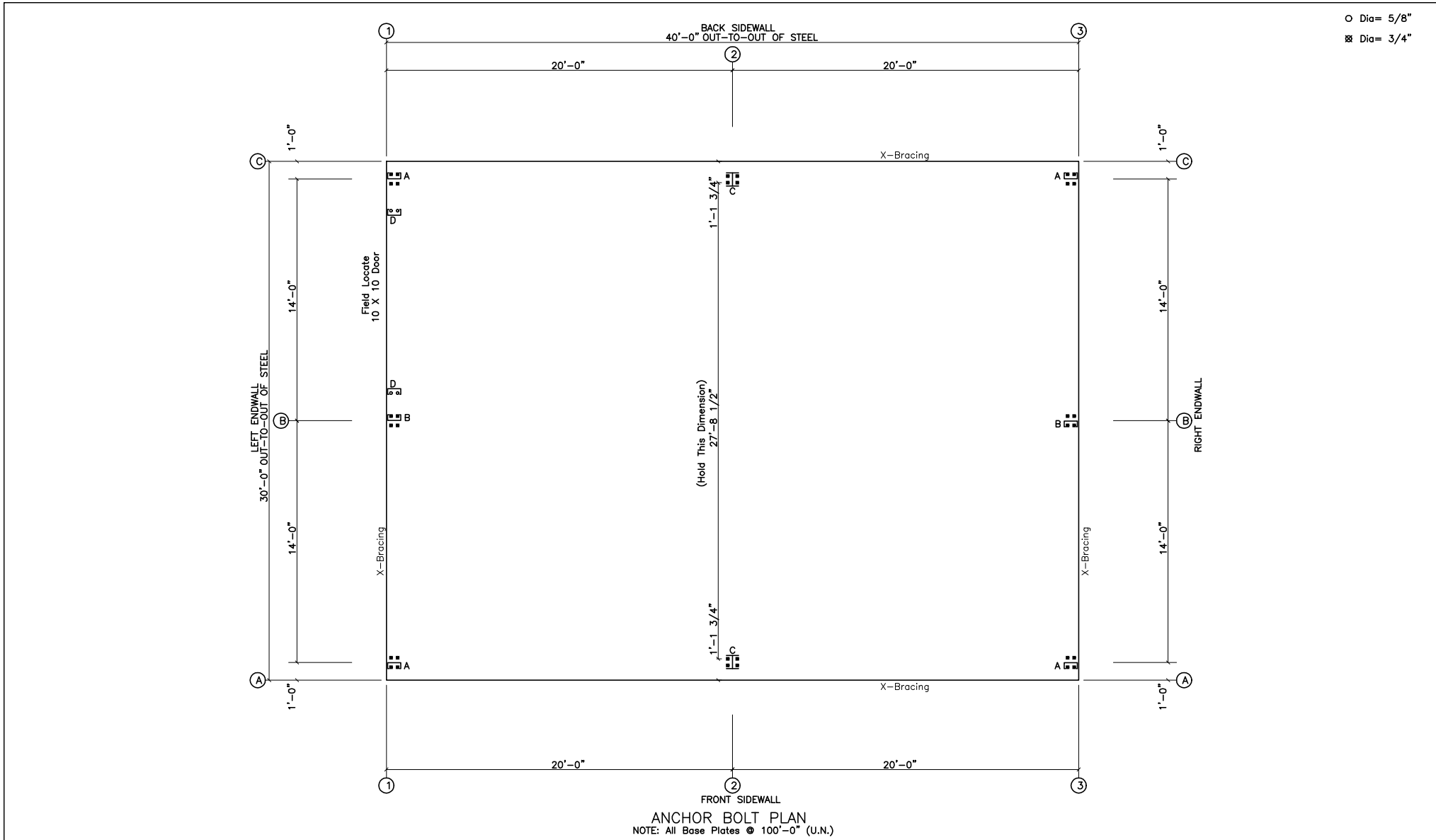

**GENERAL NOTES**

These Drawings Are Not To Scale.  
 Pinnacle's Steel Line Is Shown. A Sheeting Notch Or Brick Ledge,  
 If Used, Must Be Added To Determine The Out Of Concrete.

**ANCHOR BOLT PLAN**  
 NOTE: All Base Plates @ 100'-0" (U.N.)

ISSUE	DESCRIPTION	DATE	MARK
P	PRELIMINARY	3/ 5/15	



PO BOX 1268 - CABOT, AR 72023 (501) 941-3929

DESCRIPTION:	ANCHOR BOLT PLAN		
CUSTOMER:			
LOCATION:			
Detailer	Checker	Designer	
Job No. X304012	Sheet	Issue	P

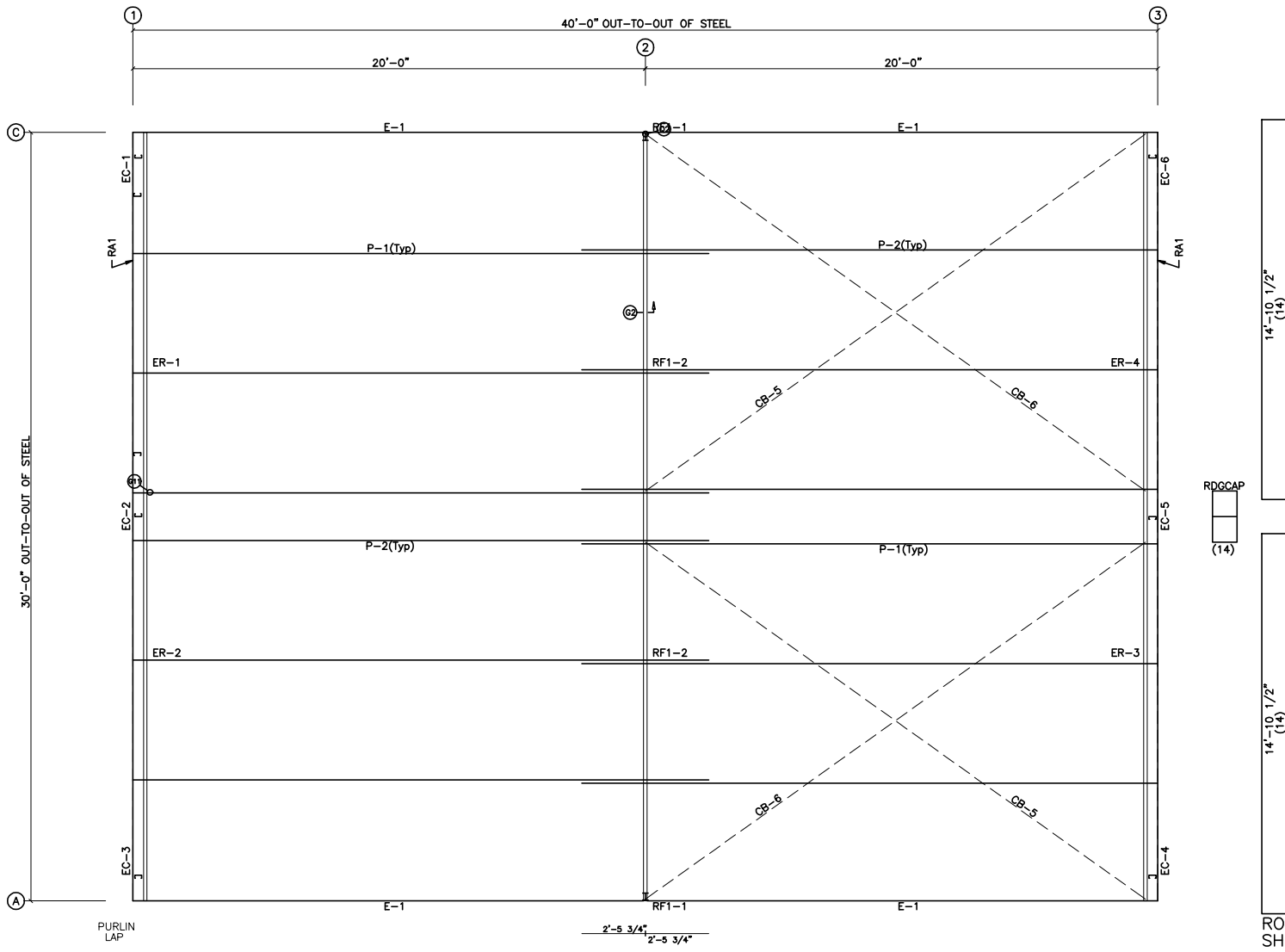

ROOF FRAMING PLAN

14'-10, 1/2"  
(14)

RDGCAP  
(14)

14'-10, 1/2"  
(14)

ROOF SHEETING  
PANELS: 26 Ga. 6PBR Galvalume

PURLIN LAP

2'-5 3/4"  
2'-5 3/4"

ISSUE	DESCRIPTION	DATE	MARK
P	PRELIMINARY	3/ 5/15	



DESCRIPTION:	ROOF FRAMING		
CUSTOMER:			
LOCATION:			
Detailer	Checker	Designer	
Job No. X304012	Sheet	Issue	P

SPlice PLATE & BOLT TABLE									
Mark	Qty		Int	Type	Dia	Length	Width	Thick	Length
	Top	Bot							
SP-1	4	4	0	A325	3/4"	2"	6"	1/2"	1'-2 3/8"
SP-2	4	4	0	A325	3/4"	1 3/4"	6"	3/8"	1'-2 3/8"

▽ FLANGE BRACES: (1) One Side; (2) Two Sides  
 FBxxA(1): xx=length(in)  
 A = L2X2X1/8

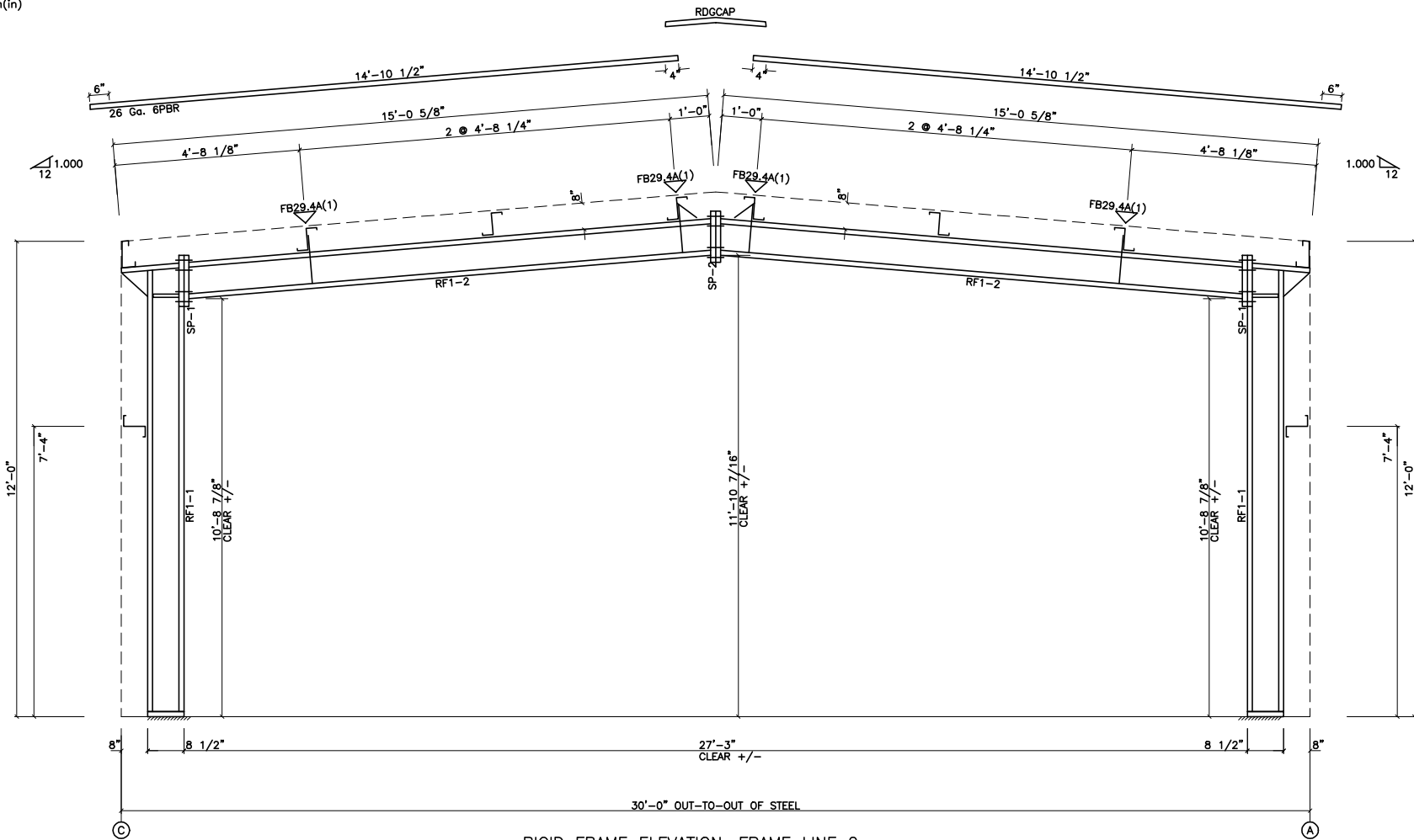

RIGID FRAME ELEVATION: FRAME LINE 2

ISSUE	DESCRIPTION	DATE	MARK
P	PRELIMINARY	3/ 5/15	



DESCRIPTION:	RIGID FRAME ELEVATION		
CUSTOMER:			
LOCATION:			
Detailer:	Checker:	Designer:	
Job No. X304012	Sheet:	Issue P	

BOLT TABLE				
FRAME LINE 1 & 3				
LOCATION	QUAN	TYPE	DIA	LENGTH
ER-1/ER-2	4	A325	5/8"	1 3/4"
ER-3/ER-4	4	A325	5/8"	1 3/4"
Columns/Raf	2	A325	5/8"	1 1/2"
Jamb	2	A325	5/8"	1 1/2"

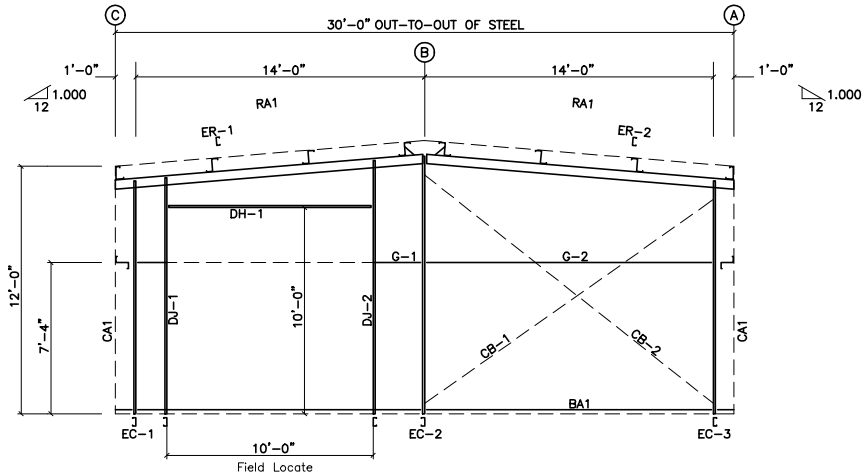

ENDWALL FRAMING: FRAME LINE 1

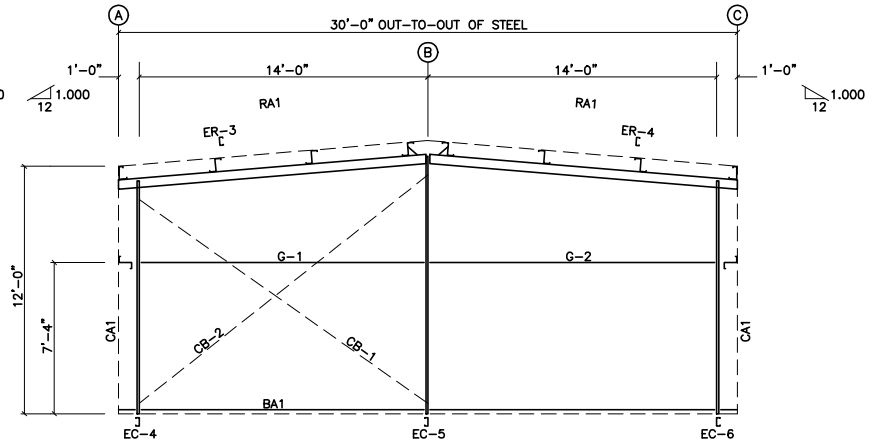

ENDWALL FRAMING: FRAME LINE 3

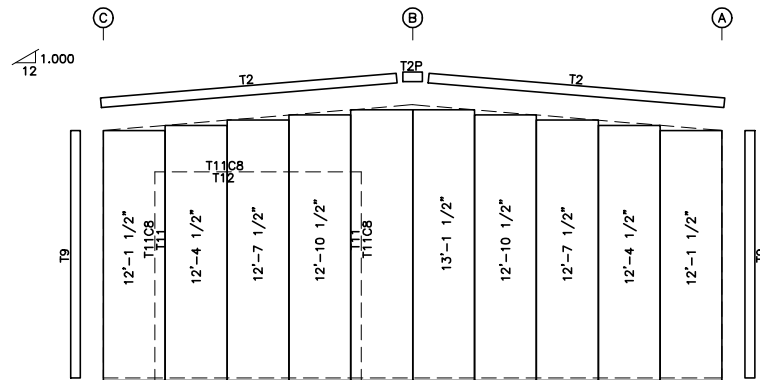

ENDWALL SHEETING & TRIM: FRAME LINE 1  
PANELS: 26 Ga. 6PBR - Sil Poly

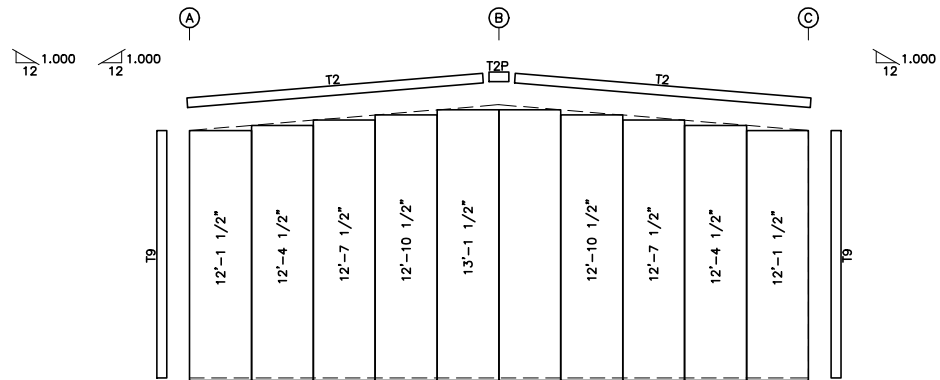

ENDWALL SHEETING & TRIM: FRAME LINE 3  
PANELS: 26 Ga. 6PBR - Sil Poly

GENERAL NOTES:

1. Pinnacle standard trim lap is 3 inches max.
2. Pinnacle pre-cuts wall panels at factory located openings as required.
3. Slot girts in field for cable passage at flush walls as required.

ISSUE	DESCRIPTION	DATE	MARK
P	PRELIMINARY	3/ 5/15	



PO BOX 1268 - CABOT, AR 72023 (501) 941-3929

DESCRIPTION:	ENDWALL FRAMING		
CUSTOMER:			
LOCATION:			
Detailer	Checker	Designer	
Job No. X304012	Sheet	Issue	P

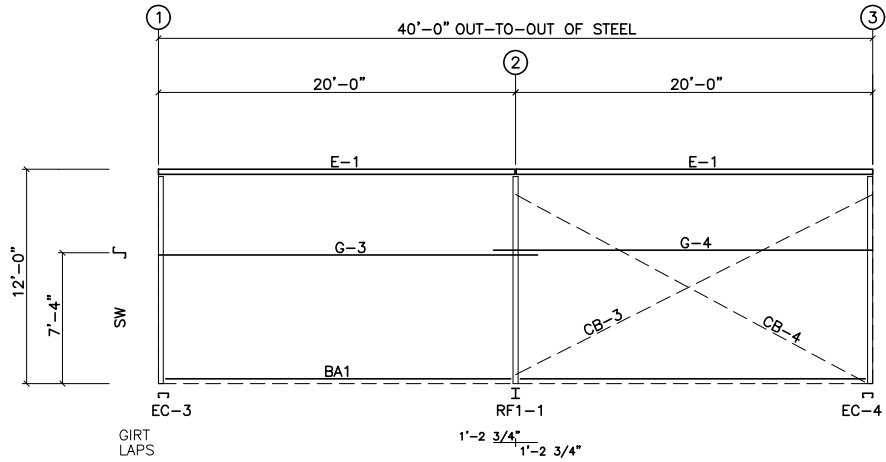

SIDEWALL FRAMING: FRAME LINE A

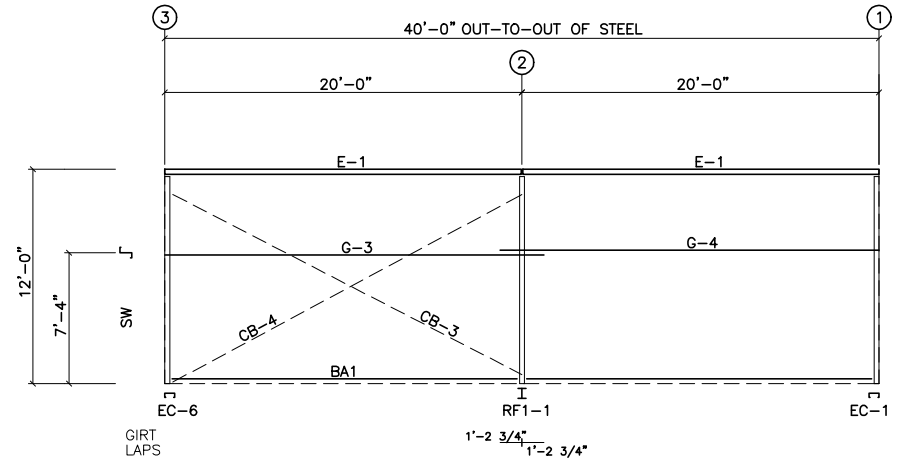

SIDEWALL FRAMING: FRAME LINE C

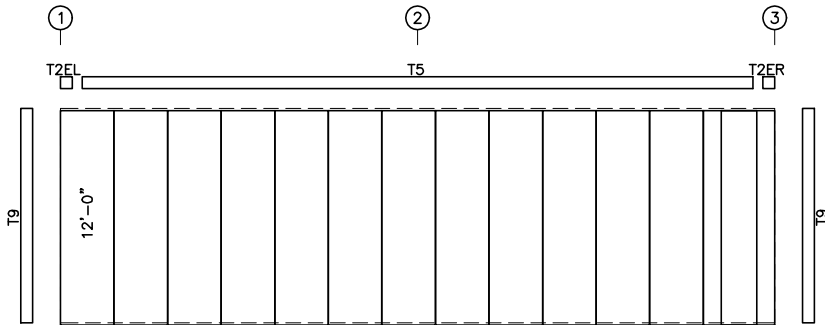

SIDEWALL SHEETING & TRIM: FRAME LINE A  
PANELS: 26 Ga. 6PBR - Sil Poly

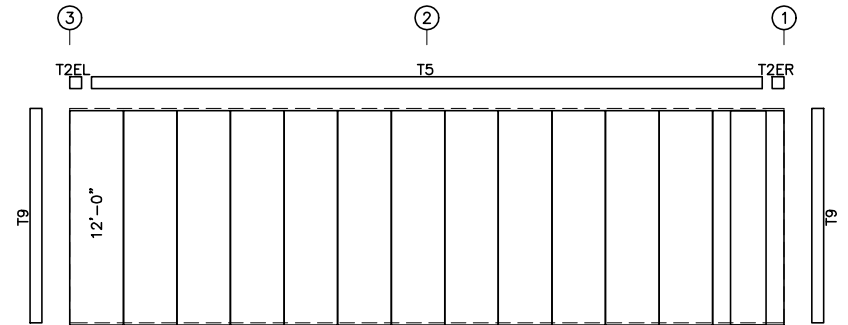

SIDEWALL SHEETING & TRIM: FRAME LINE C  
PANELS: 26 Ga. 6PBR - Sil Poly

GENERAL NOTES:

1. Pinnacle standard trim lap is 3 inches max.
2. Pinnacle pre-cuts wall panels at factory located openings as required.
3. Slot girts in field for cable passage at flush walls as required.

ISSUE	DESCRIPTION	DATE	MARK
P	PRELIMINARY	3/ 5/15	



PO BOX 1268 - CABOT, AR 72023 (501) 941-3929

DESCRIPTION:	SIDEWALL FRAMING		
CUSTOMER:			
LOCATION:			
Detailer	Checker	Designer	
Job No. X304012	Sheet	Issue	P