

X406012-3

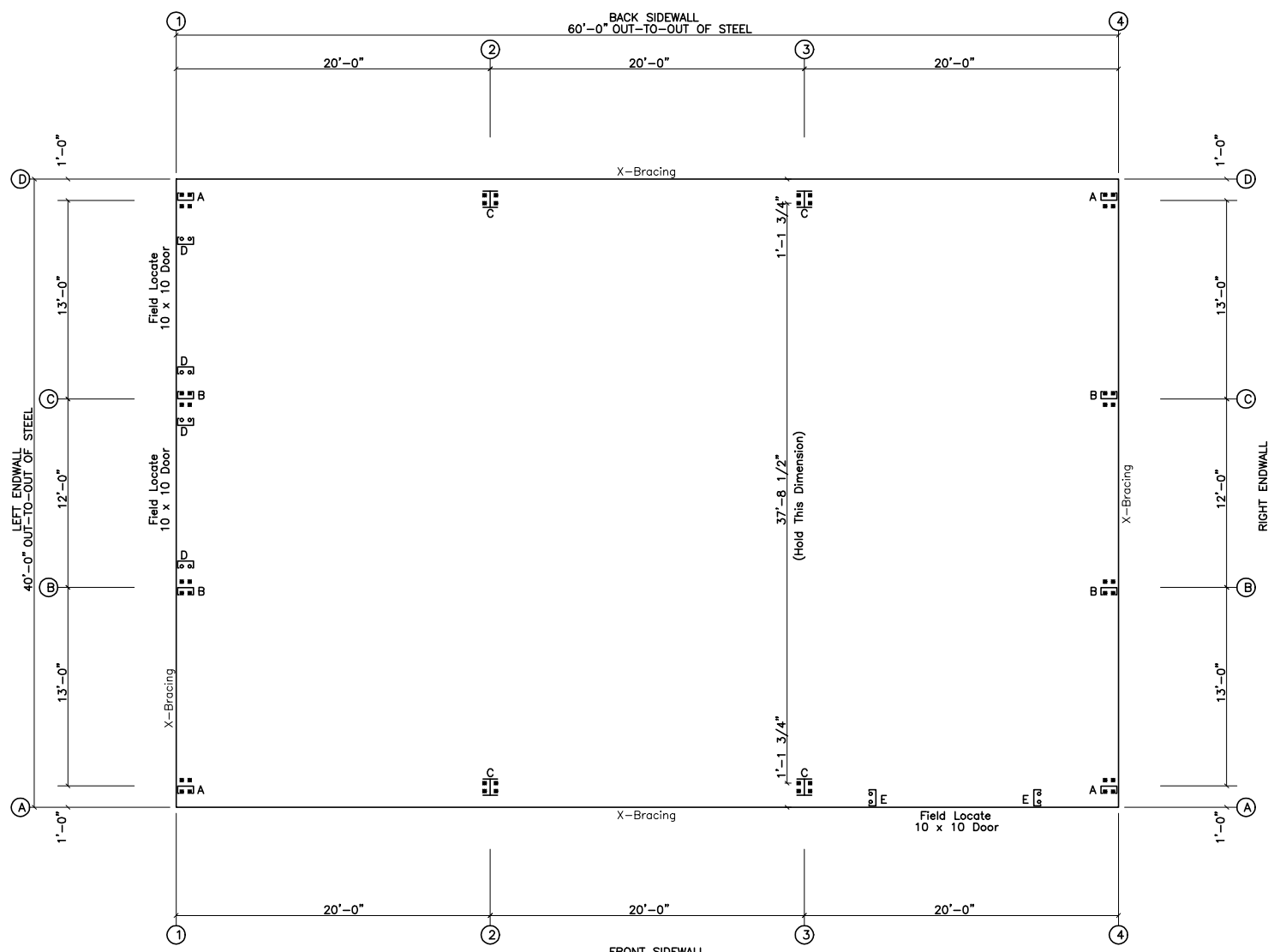

○ Dia= 5/8"
 ⌘ Dia= 3/4"

ANCHOR BOLT PLAN
 NOTE: All Base Plates @ 100'-0" (U.N.)

GENERAL NOTES

These Drawings Are Not To Scale.
 Pinnacle's Steel Line Is Shown. A Sheeting Notch Or Brick Ledge,
 If Used, Must Be Added To Determine The Out Of Concrete.

ISSUE	DESCRIPTION	DATE	MARK
P	PRELIMINARY	3/ 5/15	



DESCRIPTION:	ANCHOR BOLT PLAN		
CUSTOMER:			
LOCATION:			
Detailer	Checker	Designer	
Job No. X406012	Sheet	Issue	P

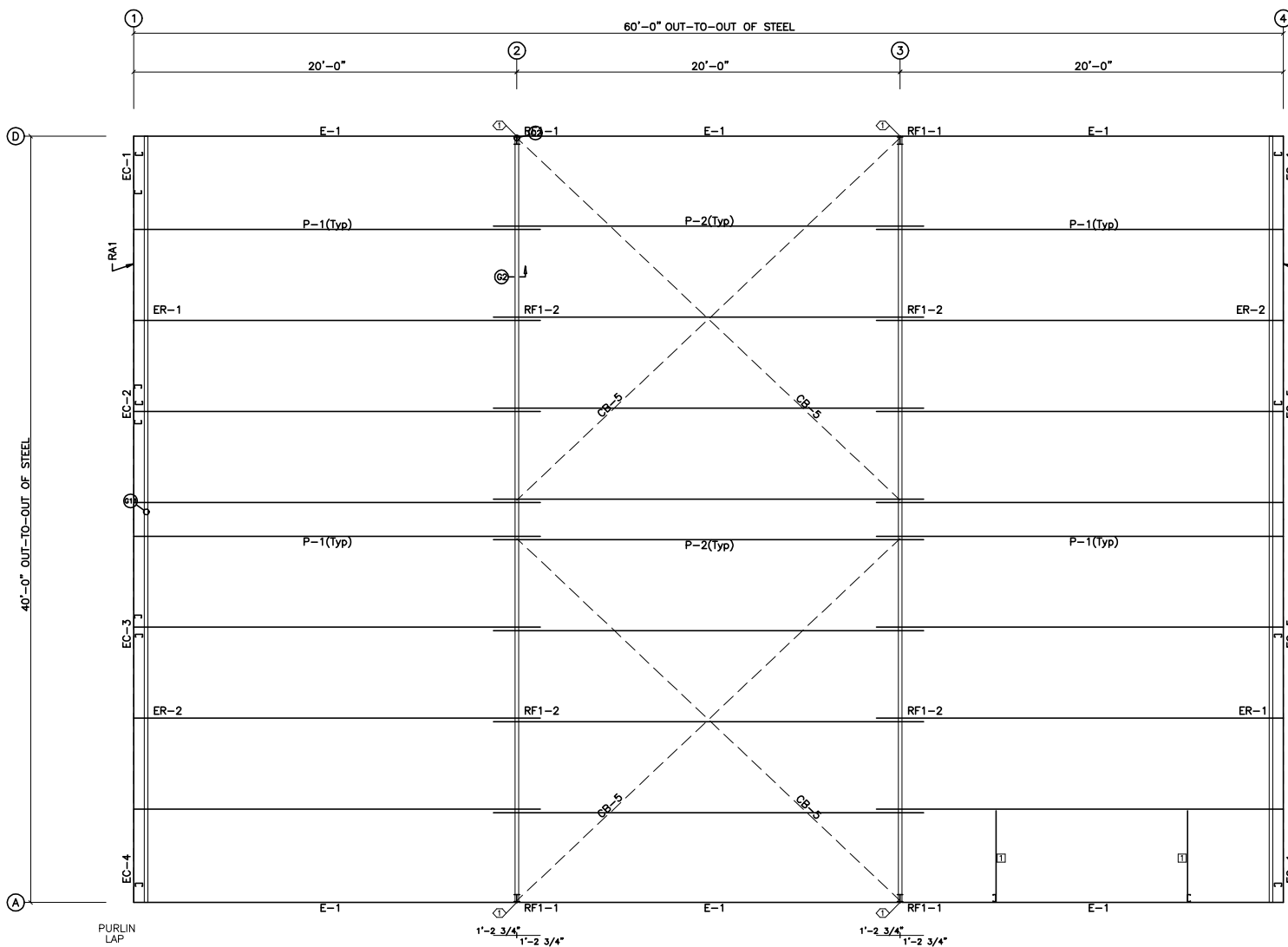

SPECIAL BOLTS					
ROOF PLAN					
Ø ID	QUAN	TYPE	DIA	LENGTH	WASH
1	2	A325	1/2"	1 1/4"	2

CONNECTION PLATES		
ROOF PLAN		
Ø ID	MARK	PART
1	L2X2X1/8	

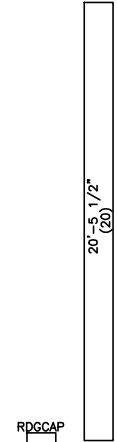

ROOF FRAMING PLAN

ROOF SHEETING
 PANELS: 26 Ga. 6PBR Galvalume

ISSUE	DESCRIPTION	DATE	MARK
P	PRELIMINARY	3/ 5/15	



DESCRIPTION:	ROOF FRAMING		
CUSTOMER:			
LOCATION:			
Detailer	Checker	Designer	
Job No. X406012	Sheet	Issue	P

SPLICE PLATE & BOLT TABLE									
Mark	Qty		Int	Type	Dia	Length	Width	Thick	Length
	Top	Bot							
SP-1	4	4	0	A325	3/4"	2 1/4"	6"	5/8"	1'-5 5/8"
SP-2	4	4	0	A325	3/4"	1 3/4"	6"	3/8"	1'-3 5/8"

▽ FLANGE BRACES: (1) One Side; (2) Two Sides
 FBxxA(1): xx=length(in)
 A = L2X2X1/8

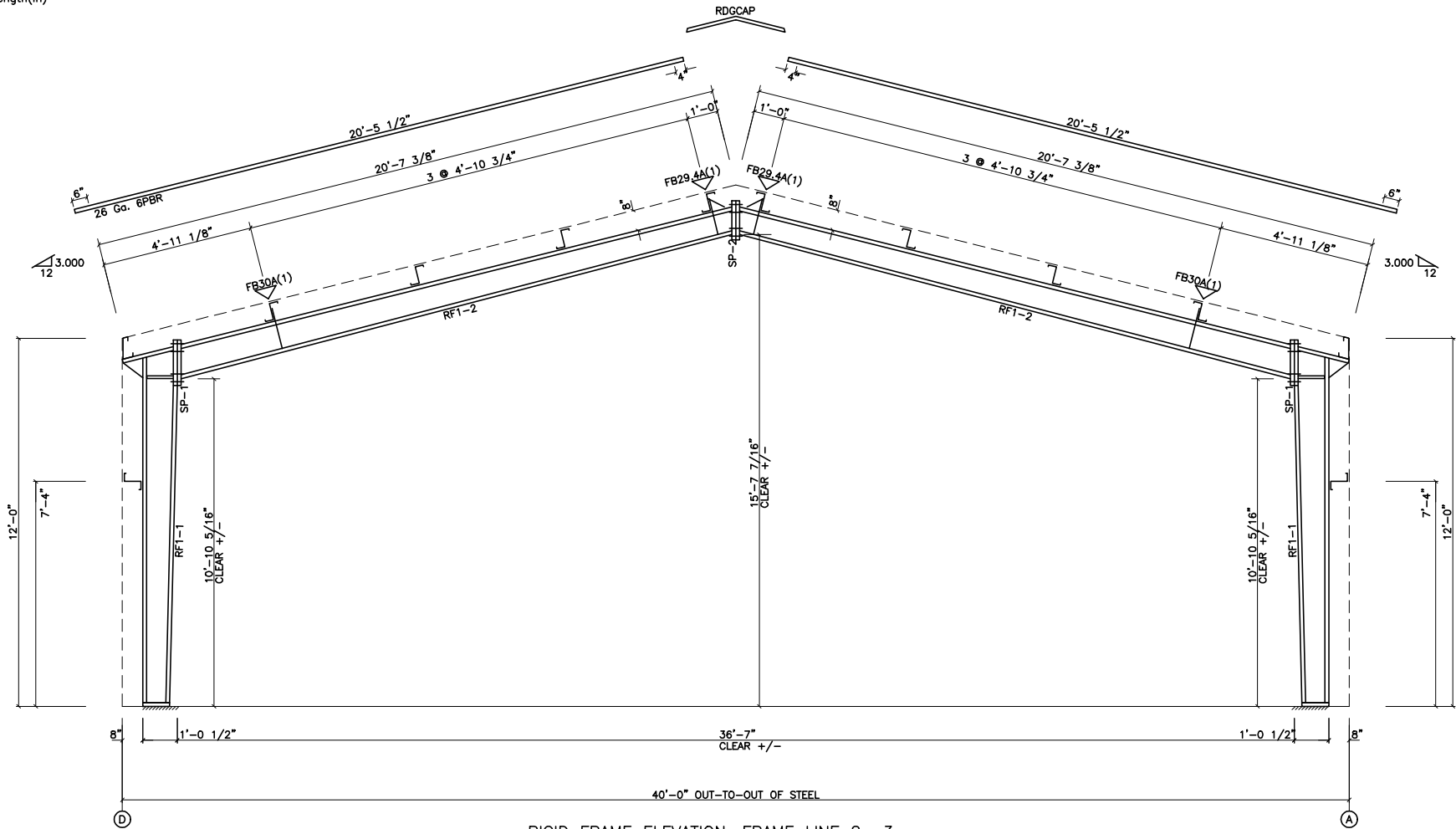

RIGID FRAME ELEVATION: FRAME LINE 2 3

ISSUE	DESCRIPTION	DATE	MARK
P	PRELIMINARY	3/ 5/15	



DESCRIPTION:	RIGID FRAME ELEVATION	
CUSTOMER:		
LOCATION:		
Detailer	Checker	Designer
Job No. X406012	Sheet	Issue P

BOLT TABLE				
FRAME LINE 1 & 4				
LOCATION	QUAN	TYPE	DIA	LENGTH
ER-1/ER-2	4	A325	5/8"	1 1/2"
Columns/Raf	2	A325	5/8"	1 1/2"
Jamb	2	A325	5/8"	1 1/2"

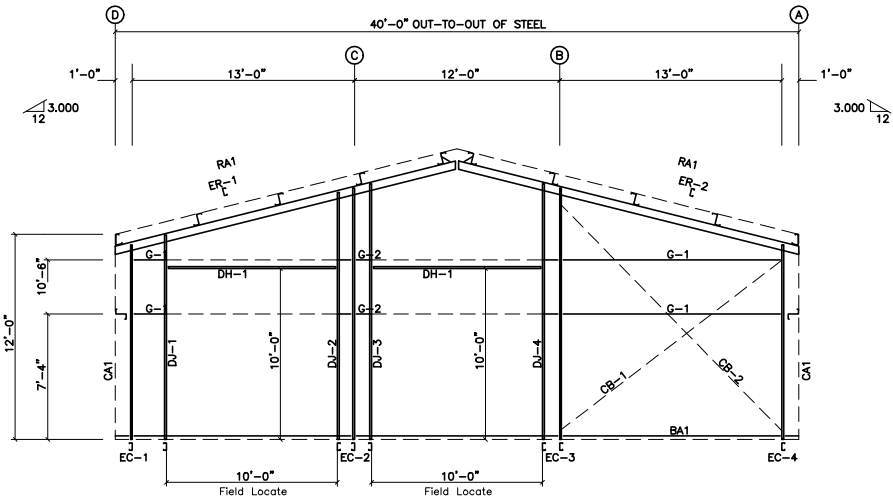

ENDWALL FRAMING: FRAME LINE 1

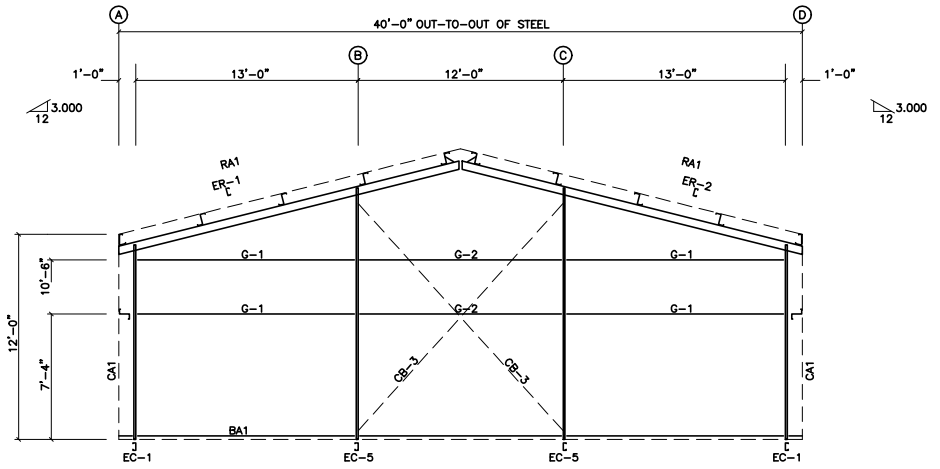

ENDWALL FRAMING: FRAME LINE 4

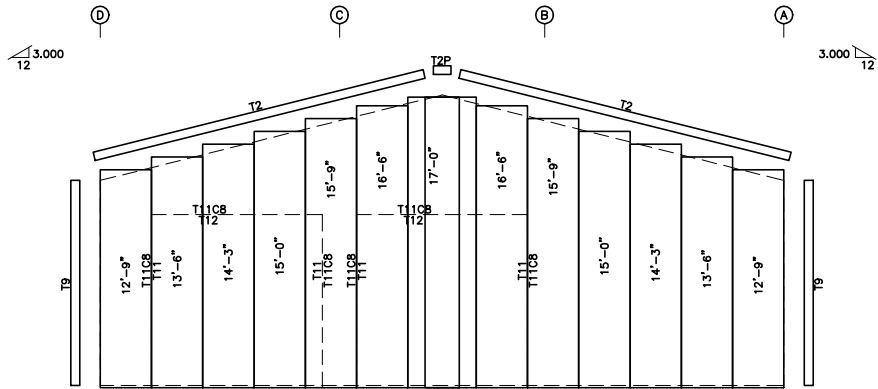

ENDWALL SHEETING & TRIM: FRAME LINE 1
PANELS: 26 Ga. 6PBR - SII Poly

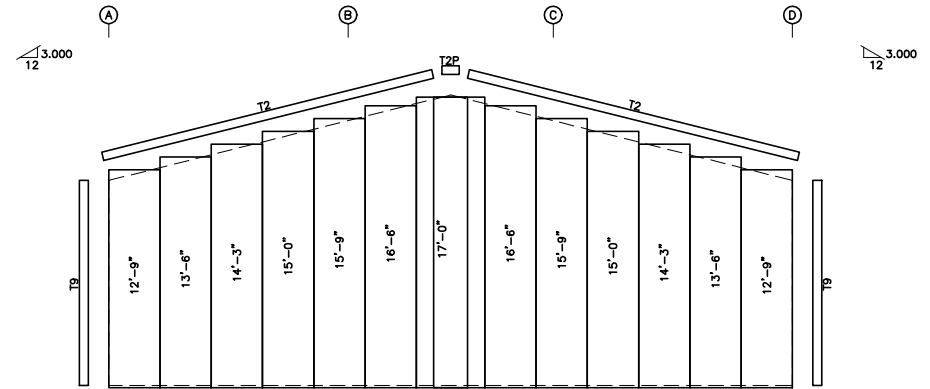

ENDWALL SHEETING & TRIM: FRAME LINE 4
PANELS: 26 Ga. 6PBR - SII Poly

GENERAL NOTES:

1. Pinnacle standard trim lap is 3 inches max.
2. Pinnacle pre-cuts wall panels at factory located openings as required.
3. Slot girts in field for cable passage at flush walls as required.

ISSUE	DESCRIPTION	DATE	MARK
P	PRELIMINARY	3/ 5/15	



DESCRIPTION:	ENDWALL FRAMING		
CUSTOMER:			
LOCATION:			
Detailer:	Checker:	Designer:	
Job No. X406012	Sheet	Issue	P

PO BOX 1268 - CABOT, AR 72023 (501) 941-3929

SPECIAL BOLTS						
Ø	ID	QUAN	TYPE	DIA	LENGTH	WASH
2		2	A325	1/2"	1 1/4"	2

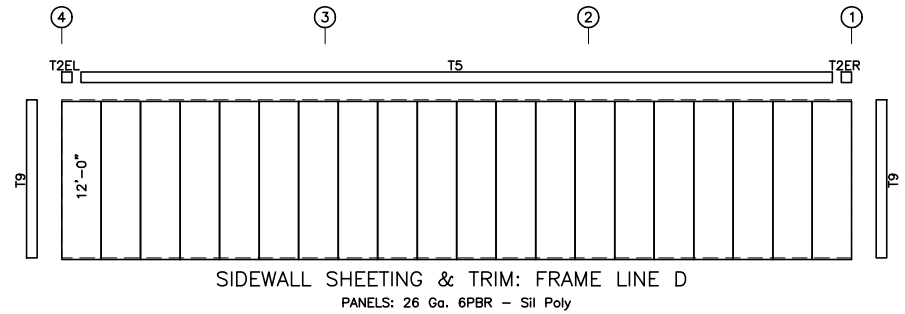
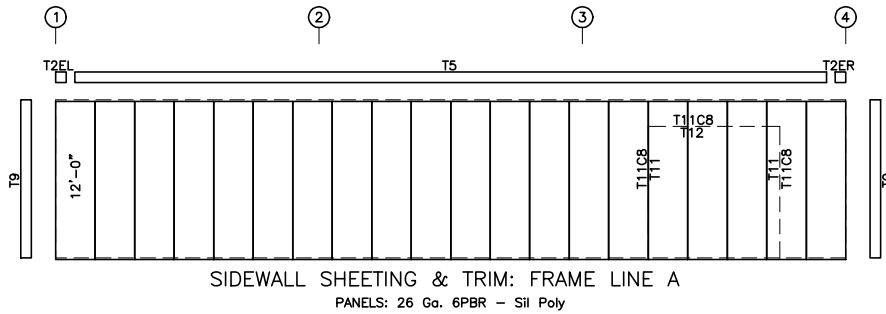
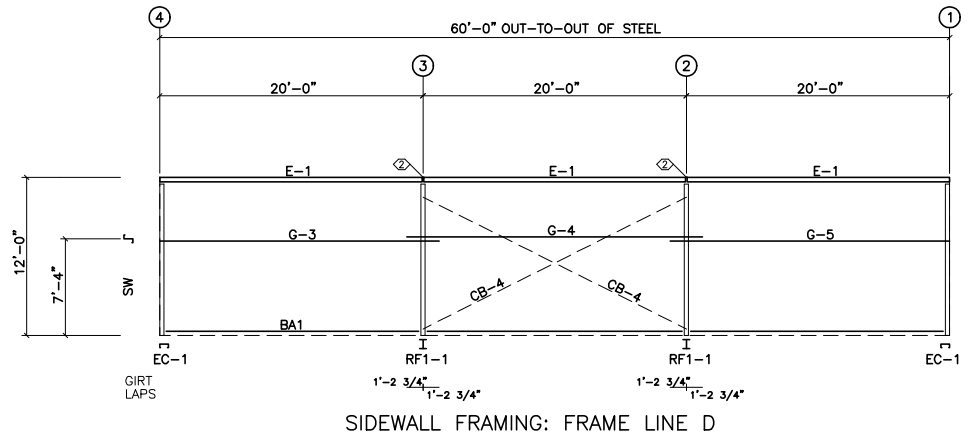
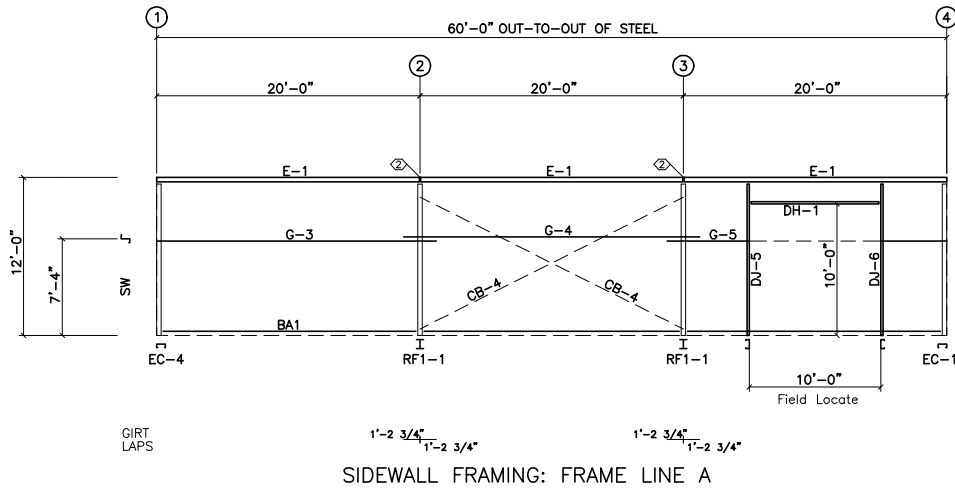

GENERAL NOTES:

1. Pinnacle standard trim lap is 3 inches max.
2. Pinnacle pre-cuts wall panels at factory located openings as required.
3. Slot girts in field for cable passage at flush walls as required.

ISSUE	DESCRIPTION	DATE	MARK
P	PRELIMINARY	3/ 5/15	



PO BOX 1268 - CABOT, AR 72023 (501) 941-3929

DESCRIPTION:	SIDEWALL FRAMING		
CUSTOMER:			
LOCATION:			
Detailer:	Checker:	Designer:	
Job No. X406012	Sheet	Issue	P